

Product Specification

Appearance

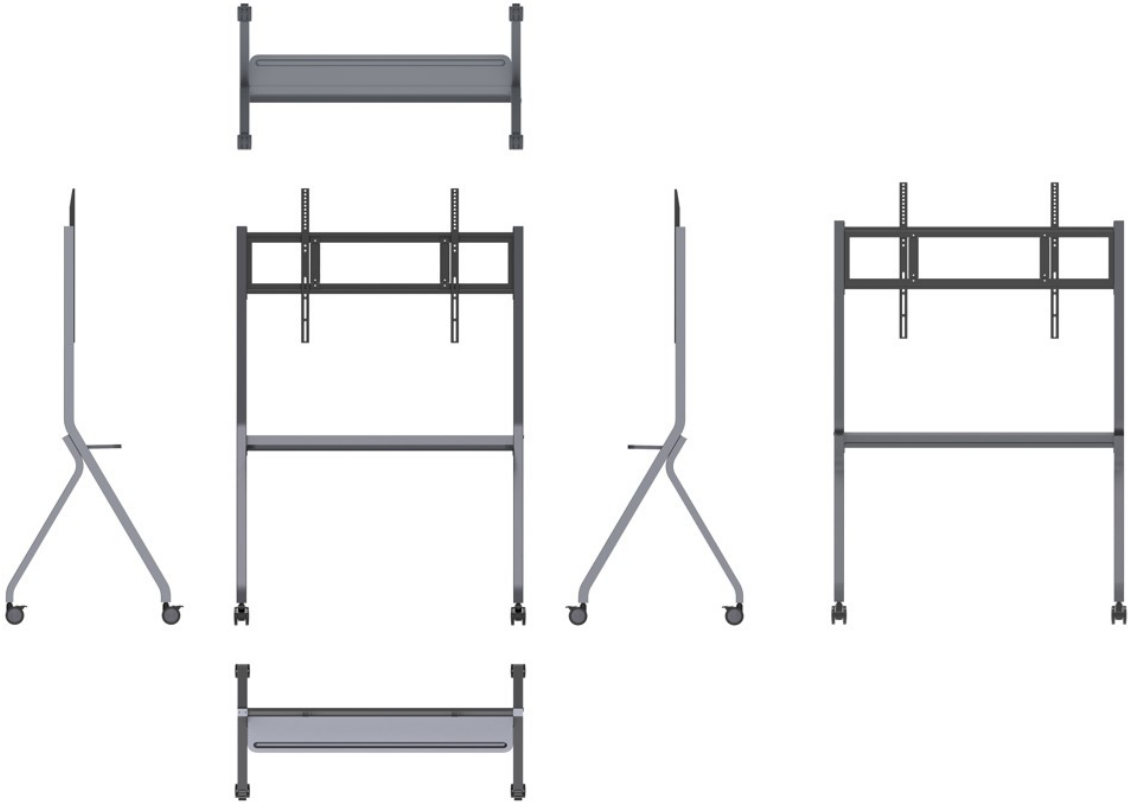

Dimensions

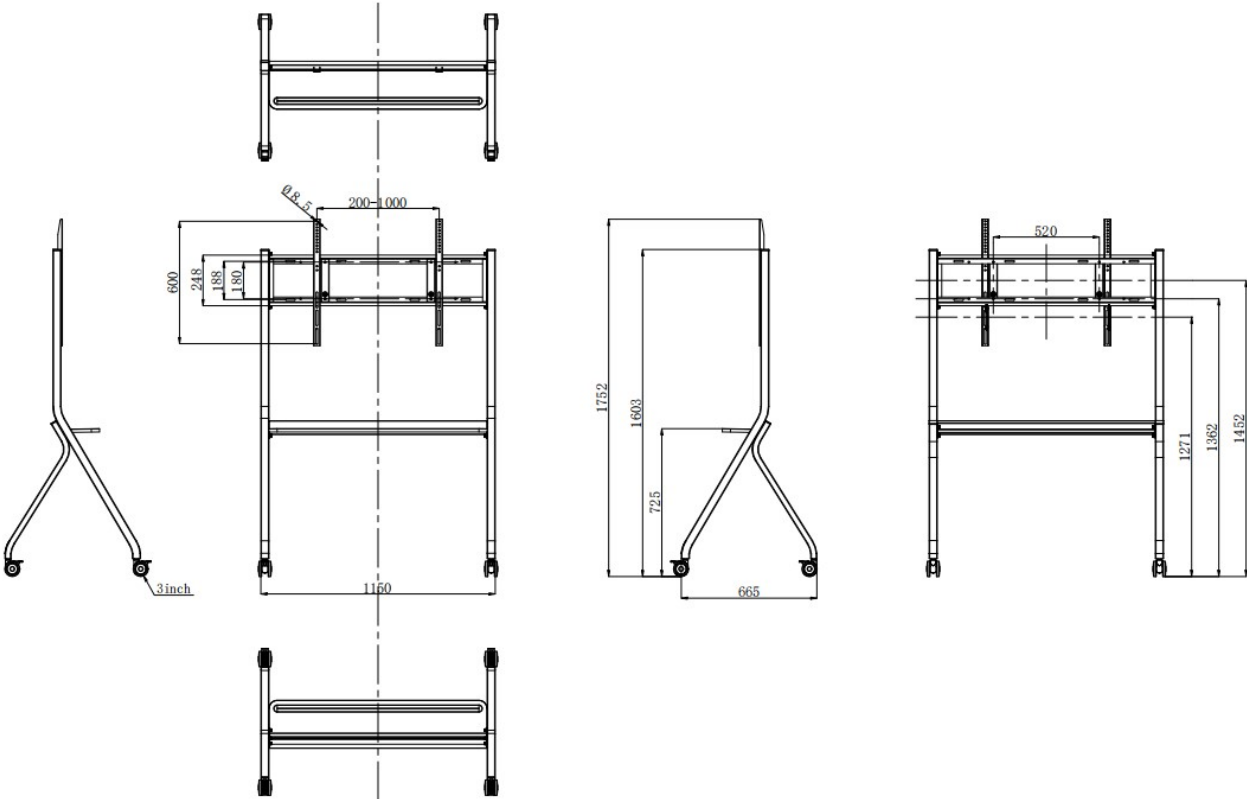

Physical Specifications

Dimension (L×W×H)	1150×665×1603mm	
Dimension with Package (L×W×H)	1630×755×160mm	
Net Weight	16.5KG	
Gross Weight	20.5KG	
Max Load	100KG	
Max Load Size	Recommend No more than 86 inch	
Castor	Size	3inch
	Type (mute /Non-mute)	mute
Matching Wall Mount	WIB6540A/WIB9060F/WIB9060G/WIB9060H	
Color	Silver gray (left&right foot,Tray) Black (wall mount)	

Accessories

Screw Accessory Package	×1
Wall mount hanging strip	×2 Optional
Installation Manual	×1

Environmental Conditions

Operation Temperature	0℃~40℃
Operation Humidity	10%~90%RH
Storage Temperature	-20℃~60℃
Storage Humidity	10%~90%RH

Statement

The product pictures of this specification only indicate that there may be slight difference in product effects (included but not limited to appearance, color and size). Please refer to the product.

Due to the influence of product configuration and manufacturing process, the actual size/weight of the fuselage may differ.

In order to provide accurate specification parameters and product characteristics as much as possible, it is possible to adjust and revise the text description and picture effect of this specification in real time, so as to match the actual product performance, specifications and other information.No special notice will be given if necessary.