

## Installing CeilingMIC Conference Room Microphones

This guide contains only the information required to install this product. Refer to the **Complete Manual for CeilingMIC Conference Room Microphones** for additional product information, compliance statements, and warranty information.

### Products Covered

This manual covers:

**CeilingMIC Conference Room Microphone** (worldwide) – 999-85100-000 (white); 999-85150-000 (black)

The CeilingMIC System is a component of the following conferencing product bundles:

- EasyTALK USB Audio Bundle – 999-86400-000 (North America); 999-86400-001 (Europe/UK); 999-86400-009 (Australia/New Zealand)
- EasyUSB MicPod I/O with two CeilingMICs – 999-88000-000 (North America); 999-88000-001 (Europe/UK)
- EasyUSB MicPod I/O with four CeilingMICs – 999-88100-000 (North America); 999-88100-001 (Europe/UK)
- ConferenceSHOT AV System with one CeilingMIC, white – 999-99950-100W (North America); 999-99950-101W (Europe/UK); 999-99950-109W (Australia/New Zealand)
- ConferenceSHOT AV System with one CeilingMIC, black – 999-99950-100 (North America); 999-99950-101 (Europe/UK); 999-99950-109 (Australia/New Zealand)
- ConferenceSHOT AV System with two CeilingMICs, white – 999-99950-200W (North America); 999-99950-201W (Europe/UK); 999-99950-209W (Australia/New Zealand)
- ConferenceSHOT AV System with two CeilingMICs, black – 999-99950-200 (North America); 999-99950-201 (Europe/UK); 999-99950-209 (Australia/New Zealand)
- ConferenceSHOT AV Camera (no speaker) with one CeilingMIC, white – 999-99950-800W (North America); 999-99950-801W (Europe/UK); 999-99950-809W (Australia/New Zealand)
- ConferenceSHOT AV Camera (no speaker) with one CeilingMIC, black – 999-99950-800 (North America); 999-99950-801 (Europe/UK); 999-99950-809 (Australia/New Zealand)
- ConferenceSHOT AV Camera (no speaker) with two CeilingMICs, white – 999-99950-700W (North America); 999-99950-701W (Europe/UK); 999-99950-709W (Australia/New Zealand)
- ConferenceSHOT AV Camera (no speaker) with two CeilingMICs, black – 999-99950-700 (North America); 999-99950-701 (Europe/UK); 999-99950-709 (Australia/New Zealand)



### What's in the Box

Make sure you received all the items you expected.

CeilingMIC System (worldwide) – 999-85100-000 (white); 999-85150-000 (black)

- In-ceiling interface box
- Microphone body and strain-relief boot (white or black)
- Tile brace
- Trim plates, qty. 2, with mounting hardware (white or black)
- Drop-down cable (white or black)
- Small zip-tie
- Strain relief clamp
- Split grommet

Contact Vaddio Technical Support if you did not receive all the items listed.

## A Quick Look at the CeilingMIC

### Interface box

- Provides AEC reference from far end and applies it to each microphone element individually
- New design emphasizes simplicity and ease of connection
- Up to 100 ft. cable distance from the interface box to the connected device

### Trim plates

- White or black, to match the microphone body
- Two-piece design can be installed after the rest of the installation is complete

### Drop-down cable

- Matches the trim ring and microphone body
- Up to 15 ft. (4.6 m) drop-down cable length supported

### Strain relief boot

- Securely grips the drop cable to prevent tension at the connector
- Split design and flexible material for easy installation
- Accommodates standard category cable; installers can build cable to length
- Clean lines for visual appeal

### Microphone body

- Three-element design with improved geometry for 360° coverage with better audio pick-up
- Each microphone element features integrated echo cancellation and Digital Signal Processing (DSP), including equalization, filtering and automatic gain control (AGC)
- Easy access to the cable connector in the microphone
- New cloth-wrapped design

### Note

Contact Vaddio Technical Support if your installation requires a drop-down cable longer than 15 ft. (4.6 m).



## Preparing for a Successful Audio Installation

Here are a few tips for avoiding common audio problems.

- The effective range for each Vaddio conference room microphone is about 12 ft. (3.7 m) under most circumstances. Be sure the room design includes enough microphones to provide adequate coverage.
- Because of the microphone geometry, sensitivity is somewhat reduced in a small area directly below the CeilingMIC. In a small to medium corporate conference room, it may make sense to suspend the CeilingMIC(s) above the centerline of the conference table.
- To prevent audio feedback, keep microphones at least 4 ft. (1.2 m) from speakers. More separation is better.
- Always place microphones closer to the people talking than to the speakers. This helps maintain quality echo cancellation.
- Do not route CeilingMIC cables across or beside fluorescent light fixtures; electrical interference from the ballasts may degrade the audio signal.
- Mount the CeilingMIC away from air vents; they can pick up the sounds of the HVAC system.
- Do not let cats play with CeilingMIC conference room microphones. (OK, that's not actually a common problem.)

## Tools You Will Need

To install the CeilingMIC, you will need:

- Hole saw for the appropriate type of ceiling
- #2 Phillips screwdriver
- Wire cutters
- Tape measure
- Ladder or lift
- Appropriate personal protective equipment

## Safety Information

Installing the CeilingMIC requires the use of a ladder or lift.

### **Warning**

*Follow standard safety practices when using ladders or lifts. Failure to do so can result in injury or death.*



### **Note**

*All above-ceiling work must conform to local building codes and should be performed by qualified personnel.*

## Don't Void Your Warranty!

### **Caution**

*This product is for indoor use. Do not install it outdoors or in a humid environment without the appropriate protective enclosure. Do not allow it to come into contact with any liquid.*

*Do not install or operate this product if it has been dropped, damaged, or exposed to liquids. If any of these things happen, return it to Vaddio for safety and functional testing.*

## Cabling Notes

### **Caution**

*Do not use pass-through RJ-45 connectors. If they are crimped incorrectly, they can damage the connectors on the product, cause intermittent connections, and degrade signal quality. Physical damage to the connectors may void your warranty.*



**Intact** – will make reliable contact with cable connector



**Damaged** – Bent contact fingers will NOT make reliable contact with cable connector

Use Cat-5e or better cable. We recommend using high-quality connectors and a high-quality crimping tool.

We recommend shielded cabling if the cables will be coiled, run tightly with other cables, or placed close sources of electromagnetic interference such as power lines.

### **Caution**

*Check your cables. Connecting a cable to the wrong port or using the wrong pin-out can result in equipment damage and will void the warranty.*

### **Pro Tip**

*Label all cables at both ends.*

## Installing the CeilingMIC

### **Warning**

Follow standard safety practices when using ladders or lifts. Failure to do so can result in injury or death. We like you, we don't want you to be injured or killed, and we hope you understand the gravity of the situation.

### Preparing the Ceiling Box

1. Remove the cover from the ceiling box.

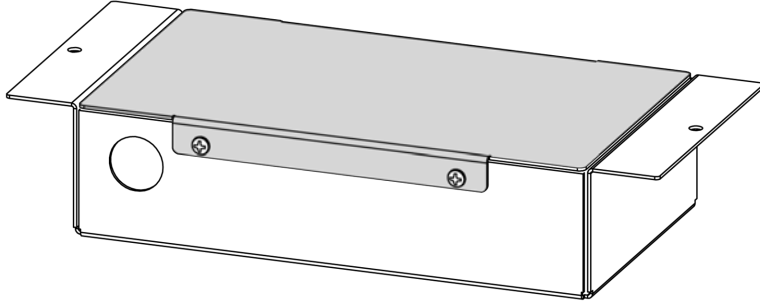

2. Determine the desired length of the drop cable, from the ceiling to the top of the microphone body (not the top of the strain relief boot). Be sure this leaves enough cable inside the ceiling box to avoid placing tension on the connector.

### **Note**

If desired, you can use a Cat-5 cable made to the desired length for the microphone drop-down cable. The cable may be up to 15 ft. (4.6 m); contact Vaddio Technical Support if your installation requires a longer drop cable.

3. Thread the drop cable through the opening in the floor of the box.
4. Snap the strain relief grommet onto the drop cable at the desired cable length, and press it into the opening in the floor of the box.
5. Connect the drop cable to the port labeled IN FROM MIC.
6. If there is excess cable above the grommet, thread a zip tie through the tie loop in the side of the box and secure the cable.



### Preparing the Ceiling

#### **If installing in a hard ceiling:**

Using the tile brace as a template, make a hole in the ceiling where the microphone will be mounted.

#### **If installing in a suspended tile ceiling:**

1. Remove the ceiling tile where the microphone will be mounted, and make a hole in the ceiling tile using the tile brace as a template.
2. Reinstall the ceiling tile and position the tile brace.

### **Note**

Because the CeilingMIC assembly weighs very little, the tile brace does not need to be physically attached to the tile support grid unless this is required by local building codes.

## Working Above the Ceiling

1. Route a Cat-5e (or better) cable from the ceiling box to the mixer or other audio device. The cable may be up to 100 ft. (30 m.) long.
2. Thread the cable through the opening in the side of the ceiling box.
3. Install the split grommet in the opening in the side of the ceiling box to keep the cable from chafing.
4. Connect the cable to the port labeled OUT TO MIXER.
5. Reinstall the cover on the ceiling box.
6. Thread the drop cable through the opening in the ceiling and place the ceiling box flat.

## Working Below the Ceiling

1. Connect the drop cable to the port in the microphone body.



2. Fit the strain relief boot over the drop cable.
3. Fit the strain relief boot into place in the microphone body.
4. Slide both the slotted trim plates over the cable, making sure the countersinks face outward, and turn them so the slots are on opposite sides. Use the 3/4 inch flat head screws to secure the trim plates to the threaded posts on the bottom of the interface box.

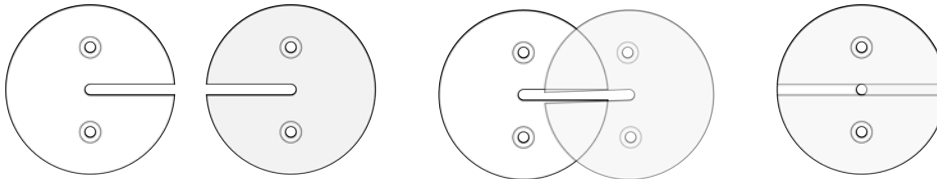

(Illustration shaded for clarity)

Contact Vaddio Technical Support if you have questions or encounter any problems. Phone 800.572.2011 / +1.763.971.4400, email [av.vaddio.support@legrand.com](mailto:av.vaddio.support@legrand.com).

## Basic Connections

This is a simple installation for a small conference room, using the CeilingMIC with a ConferenceSHOT AV system. In this installation, the CeilingMIC connects to a ConferenceSHOT AV camera with speaker. The camera connects to a computer over a USB 3 connection, making audio and video available to soft conferencing applications.

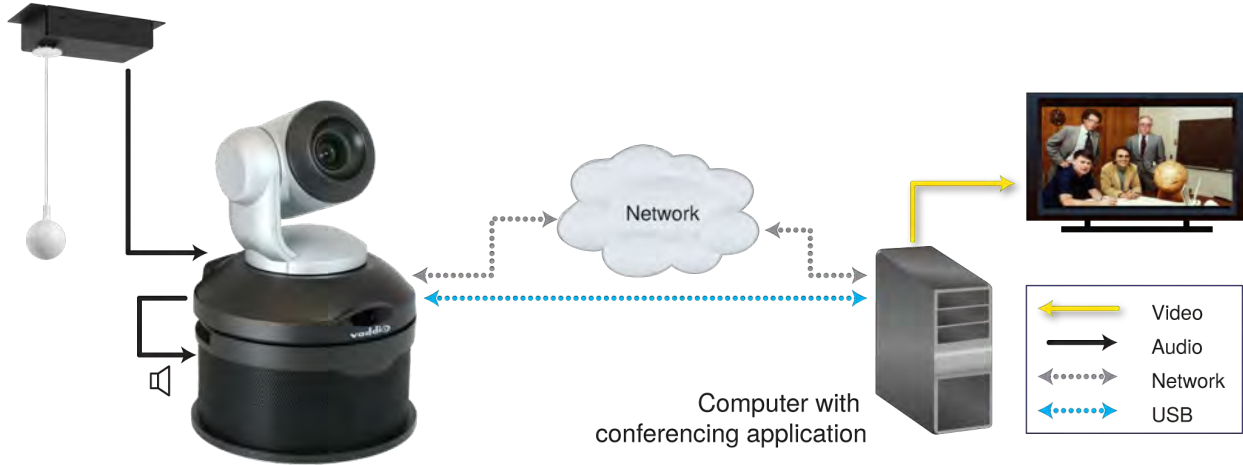

## Installing CeilingMIC Conference Room Microphones

This installation is for a larger room, using an AV Bridge MATRIX PRO to manage the room audio and video. The four CeilingMIC microphones connect directly to EasyMIC ports on the AV Bridge MATRIX PRO. The speaker(s) require an amplifier, as shown by the amplifier symbol in the diagram. This system can include multiple cameras.

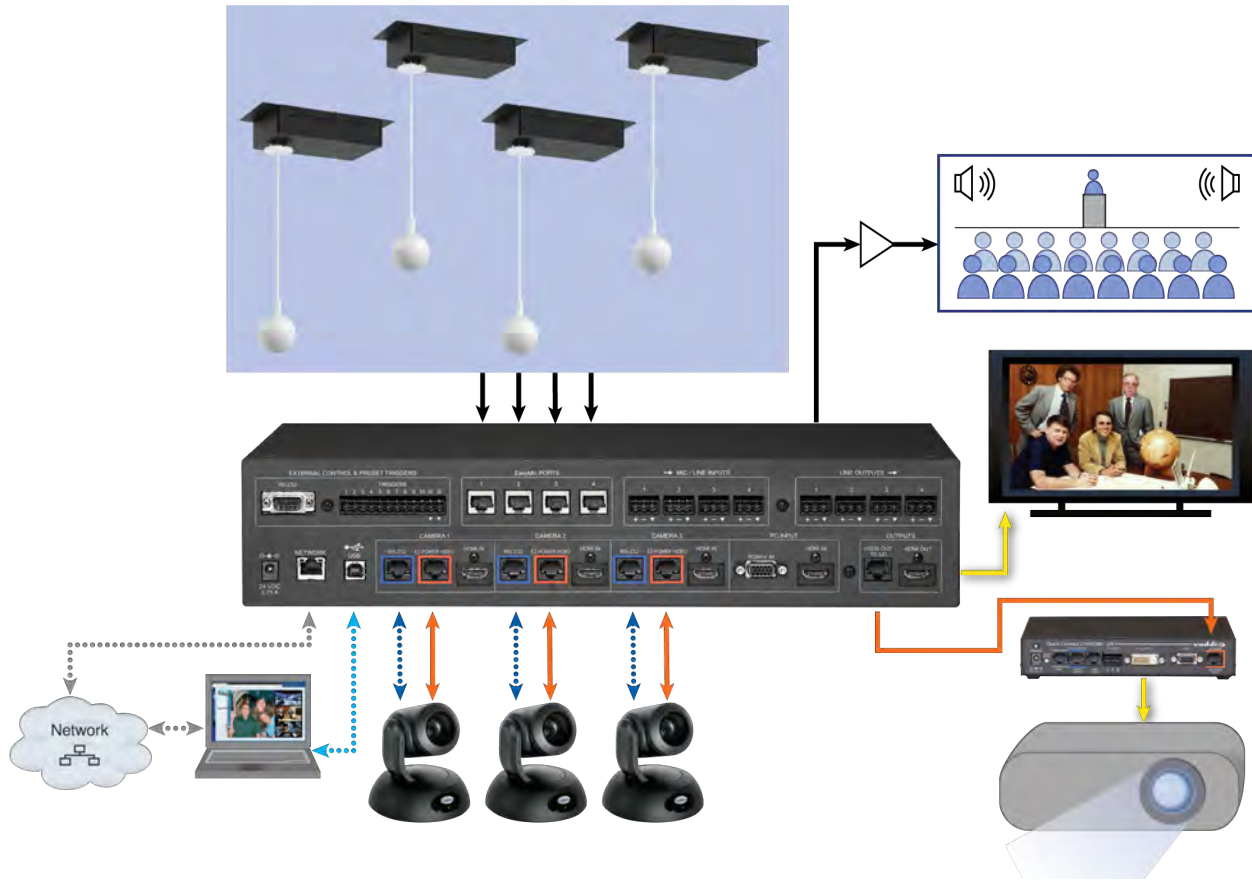

Vaddio is a brand of Legrand AV Inc. · [www.legrandav.com](http://www.legrandav.com) · Phone 800.572.2011 / +1.763.971.4400 · Fax +1.763.971.4464 · Email [av.vaddio.support@legrand.com](mailto:av.vaddio.support@legrand.com)

Visit us at [support.vaddio.com](http://support.vaddio.com) for firmware updates, specifications, drawings, manuals, technical support information, and more.

©2019 Legrand AV Inc.

Vaddio is a registered trademark of Legrand AV Inc. All other brand names or marks are used for identification purposes and are trademarks of their respective owners. All patents are protected under existing designations. Other patents pending.

**A brand of  legrand®**

**Commercial AV Brands Chief | Da-Lite | Middle Atlantic | Projecta | Vaddio**

**vaddio®**