

# INSTALLATION INSTRUCTIONS

(shown with XPAU cart)

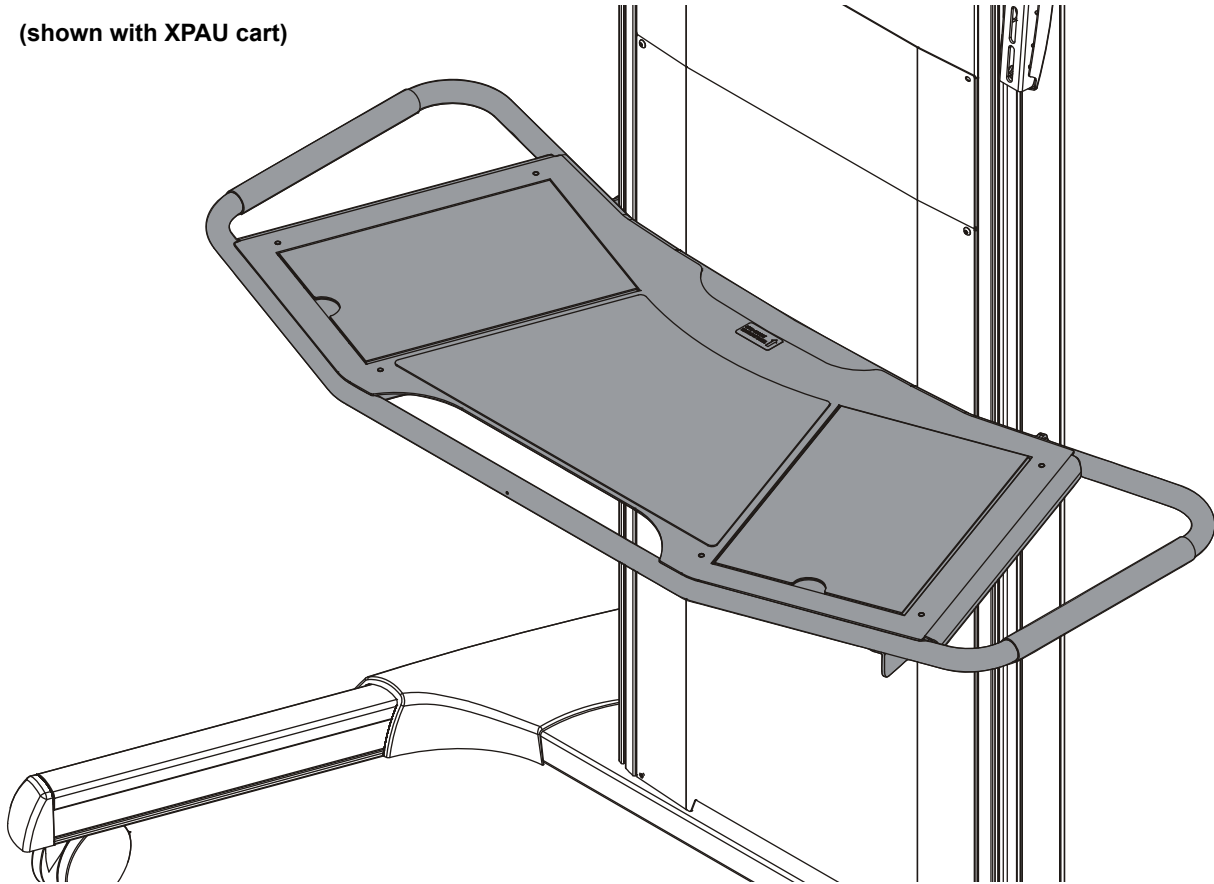

## Large Shelf for Fusion™ Cart

 **CHIEF**®

A brand of  **legrand**®

# FCA613

## DISCLAIMER

Legrand | AV and its affiliated corporations and subsidiaries (collectively "Legrand | AV"), intend to make this manual accurate and complete. However, Legrand | AV makes no claim that the information contained herein covers all details, conditions or variations, nor does it provide for every possible contingency in connection with the installation or use of this product. The information contained in this document is subject to change without notice or obligation of any kind. Legrand | AV makes no representation of warranty, expressed or implied, regarding the information contained herein. Legrand | AV assumes no responsibility for accuracy, completeness or sufficiency of the information contained in this document.

Chief® is a registered trademark of Legrand AV Inc.

## DEFINITIONS

**MOUNTING SYSTEM:** A MOUNTING SYSTEM is the primary Chief product to which an accessory and/or component is attached.

**ACCESSORY:** AN ACCESSORY is the secondary Chief product which is attached to a primary Chief product, and may have a component attached or setting on it.

**COMPONENT:** A COMPONENT is an audiovisual item designed to be attached or resting on an accessory or mounting system such as a video camera, CPU, screen, display, projector, etc.



**WARNING:** A WARNING alerts you to the possibility of serious injury or death if you do not follow the instructions.



**CAUTION:** A CAUTION alerts you to the possibility of damage or destruction of equipment if you do not follow the corresponding instructions.



## IMPORTANT SAFETY INSTRUCTIONS



**WARNING:** Failure to read, thoroughly understand, and follow all instructions can result in serious personal injury, damage to equipment, or voiding of factory warranty! It is the installer's responsibility to make sure all accessories are properly assembled and installed using the instructions provided.



**WARNING:** Exceeding the weight capacity can result in serious personal injury or damage to equipment! It is the installer's responsibility to make sure the combined weight of all components located on the FCA613 does not exceed 25 lbs (11.34 kg).



**WARNING:** Use of this accessory will decrease the weight capacity of the mounting system to which it is attached by the combined weight of the accessory and all components supported by this accessory. See figure for reference.

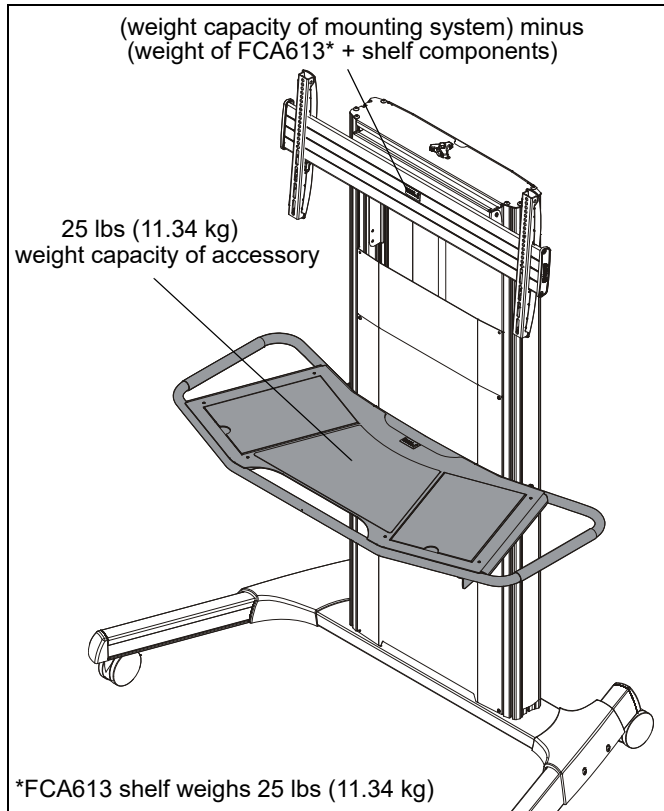

**WARNING:** Use this accessory only for its intended use as described in these instructions. Do not use attachments not recommended by the manufacturer.



**WARNING:** Never operate this accessory if it is damaged. Return the accessory to a service center for examination and repair.



**WARNING:** Do not use this product outdoors.



**WARNING:** RISK OF INJURY TO PERSONS! Do not place video equipment such as televisions or computer monitors on shelf.

**NOTE:** The FCA613 shelf is compatible with the following models:





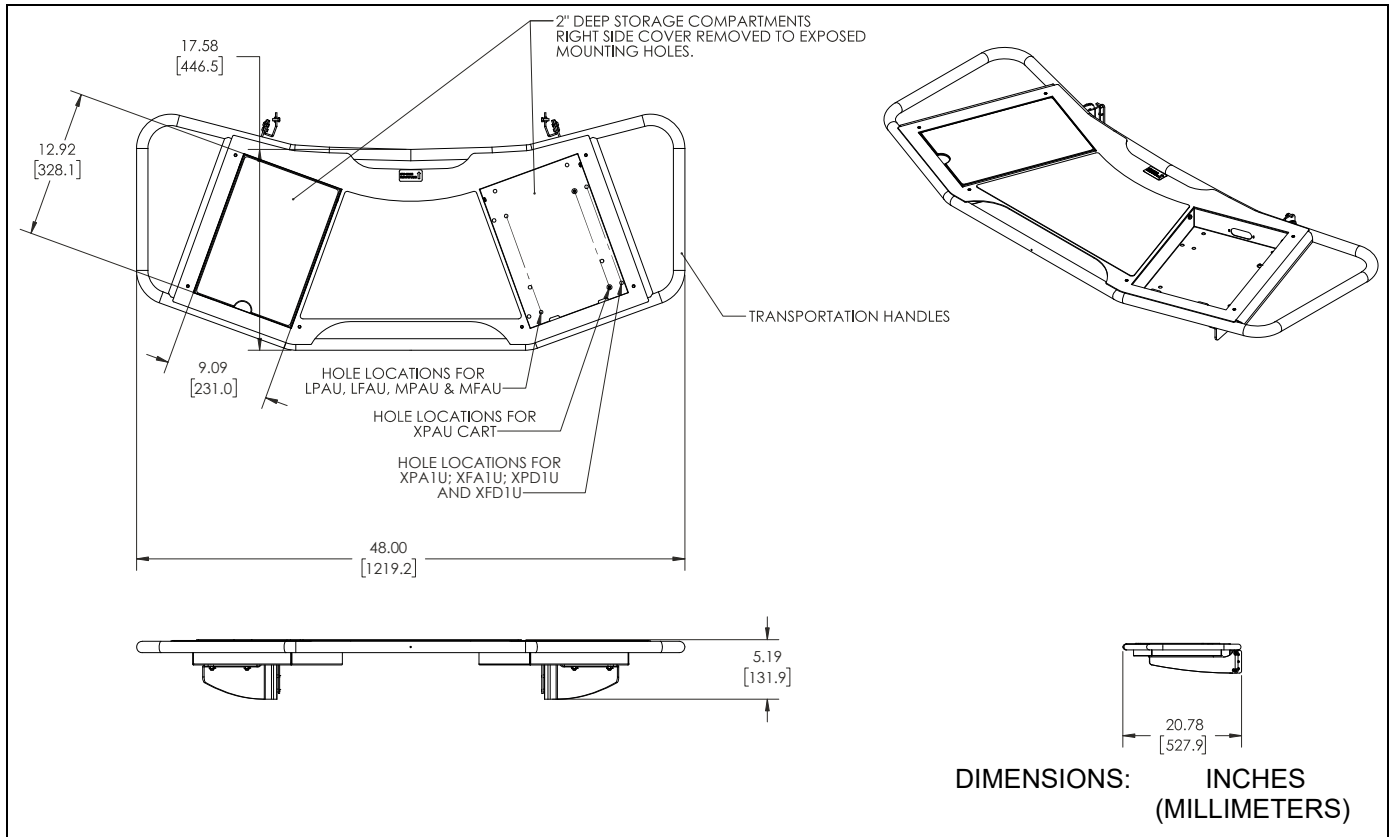

- MPAU/MFAU
- LPAU/LFAU
- XPA1U/XFA1U
- XPAU
- XPD1U/XFD1U

**--SAVE THESE INSTRUCTIONS--**

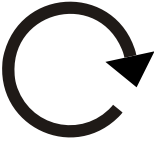
**DIMENSIONS**

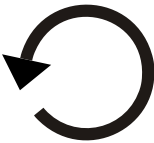

**LEGEND**

	<p><b>Tighten Fastener</b>                      Apretar elemento de fijación                      Befestigungsteil festziehen                      Apertar fixador                      Serrare il fissaggio                      Bevestiging vastdraaien                      Serrez les fixations</p>		<p><b>Pencil Mark</b>                      Marcar con lápiz                      Stiftmarkierung                      Marcar com lápis                      Segno a matita                      Potloodmerkteken                      Marquage au crayon</p>
	<p><b>Loosen Fastener</b>                      Aflojar elemento de fijación                      Befestigungsteil lösen                      Desapertar fixador                      Allentare il fissaggio                      Bevestiging losdraaien                      Desserrez les fixations</p>		<p><b>Hex-Head Wrench</b>                      Llave de cabeza hexagonal                      Sechskantschlüssel                      Chave de cabeça sextavada                      Chiave esagonale                      Zeskantsleutel                      Clé à tête hexagonale</p>
	<p><b>Phillips Screwdriver</b>                      Destornillador Phillips                      Kreuzschlitzschraubendreher                      Chave de fendas Phillips                      Cacciavite a stella                      Kruiskopschroevendraaier                      Tournevis à pointe cruciforme</p>		<p><b>Adjust</b>                      Ajustar                      Einstellen                      Ajustar                      Regolare                      Afstellen                      Ajuster</p>

**TOOLS REQUIRED FOR INSTALLATION**

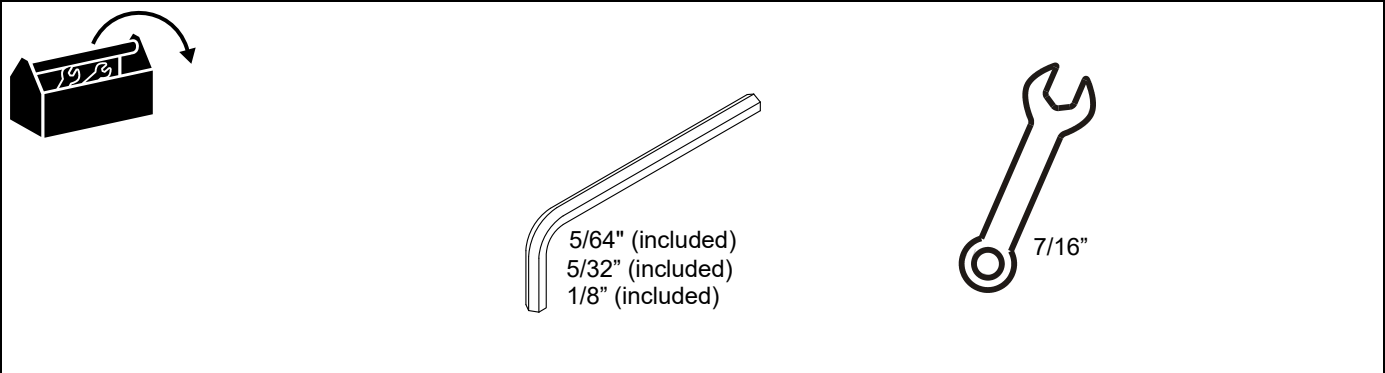

**PARTS**

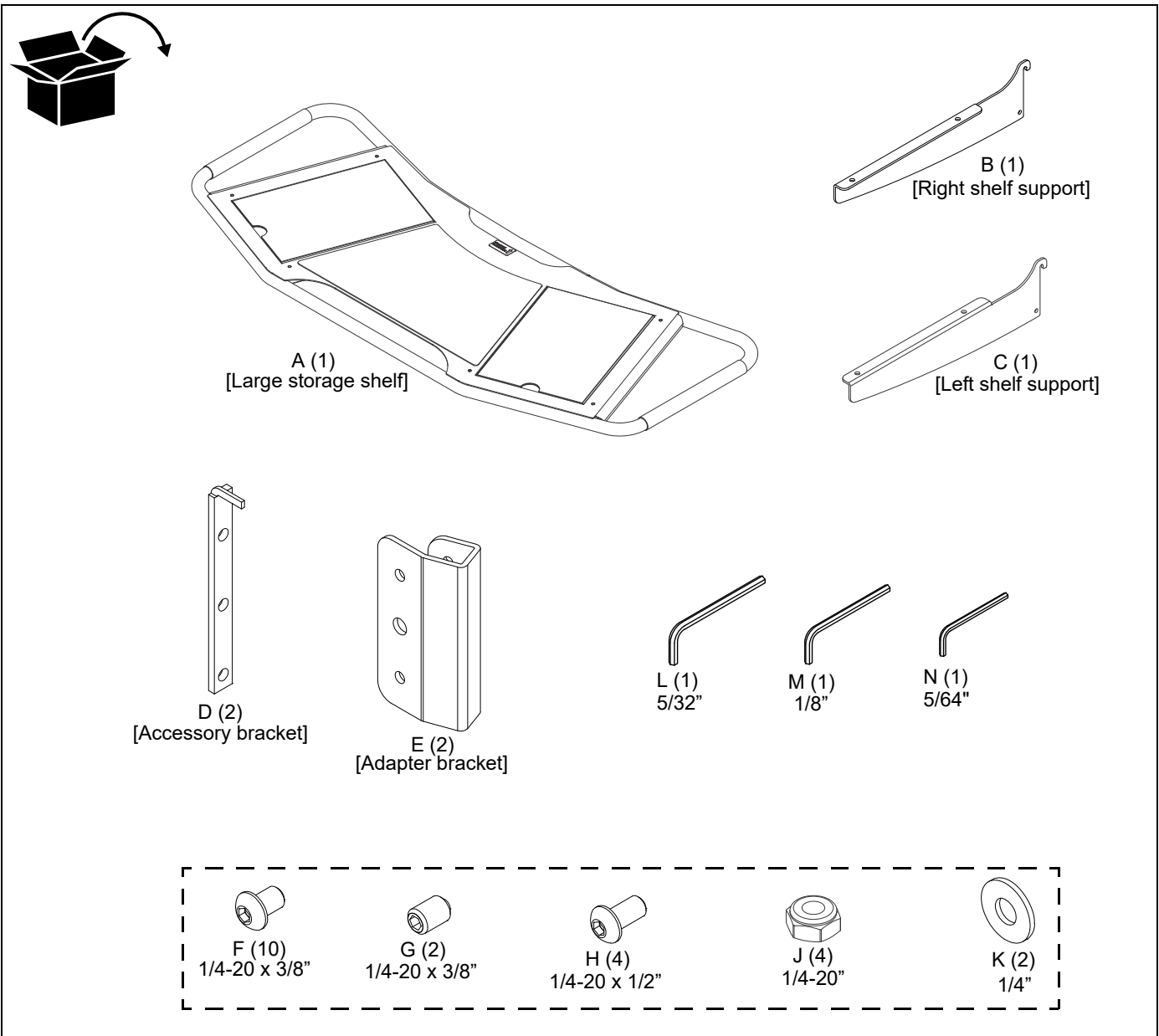

### Assembly And Installation

**NOTE:** The following procedure assumes the Fusion™ Cart/ Stand has already been completely assembled with the display attached.

**IMPORTANT ! :** The FCA613 shelf has been designed specifically for Chief's Fusion™ Series Carts and Stands. DO NOT attempt to install this shelf onto any other cart or stand!

1. (XPD1U/XFD1U ONLY) Remove tabs from top of side channels by removing screws holding them to mount. (See Figure 1)

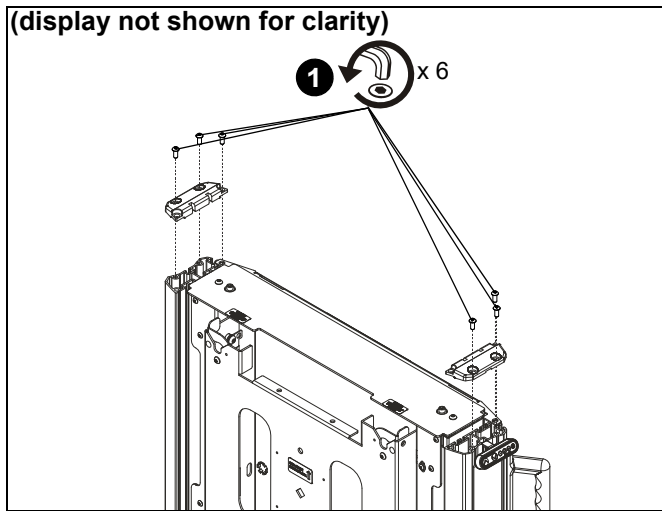

Figure 1

2. (XPD1U/XFD1U ONLY) Remove control pad from control pad bracket. (See Figure 2)
3. (XPD1U/XFD1U ONLY) Remove control pad bracket from side channel by removing screw holding it to mount using 5/64" hex key (N). (See Figure 2)

**NOTE:** Control pad may need to be disconnected and reconnected during this process. See XPD1U/XFD1U installation instructions for details.

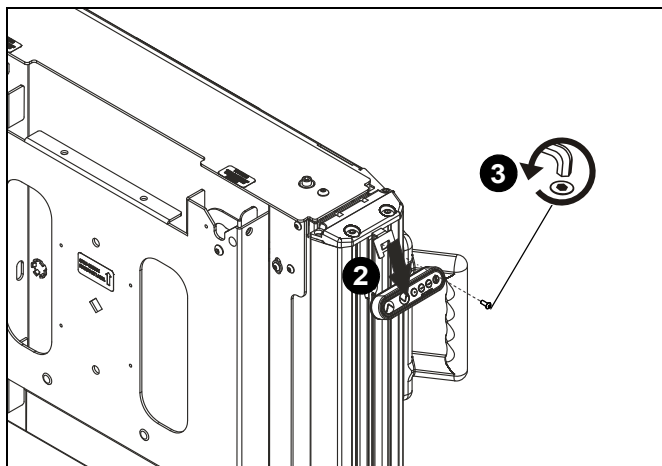

Figure 2

4. Remove side covers from cart/stand by sliding them up the channel. (See Figure 3)

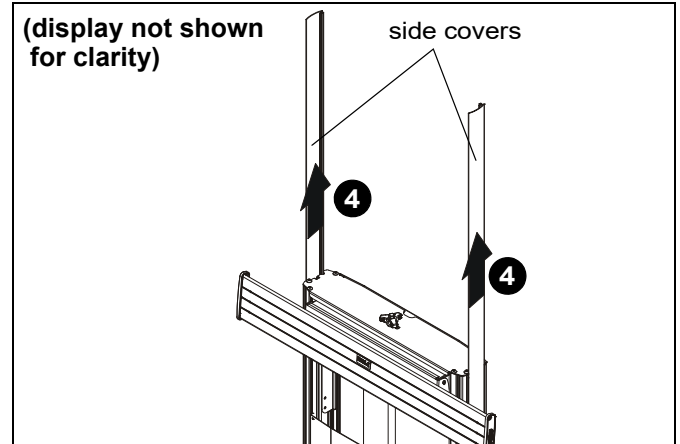

Figure 3

5. Loosely install one 1/4-20 x 3/8" set screw (G) into middle hole of each accessory bracket (D). (See Figure 4)

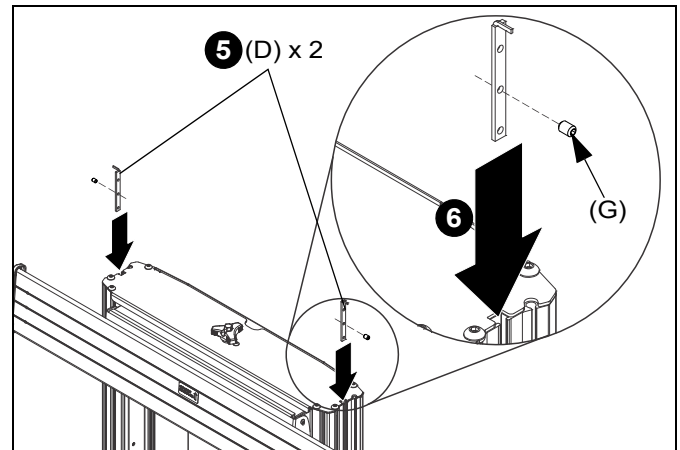

Figure 4

6. Slide accessory bracket (D) down side channel to desired height and tighten set screw. (See Figure 4)
7. Install two 1/4-20 x 3/8" button head cap screws (F) through upper and lower holes on adapter bracket (E) and accessory bracket (D). (See Figure 5)

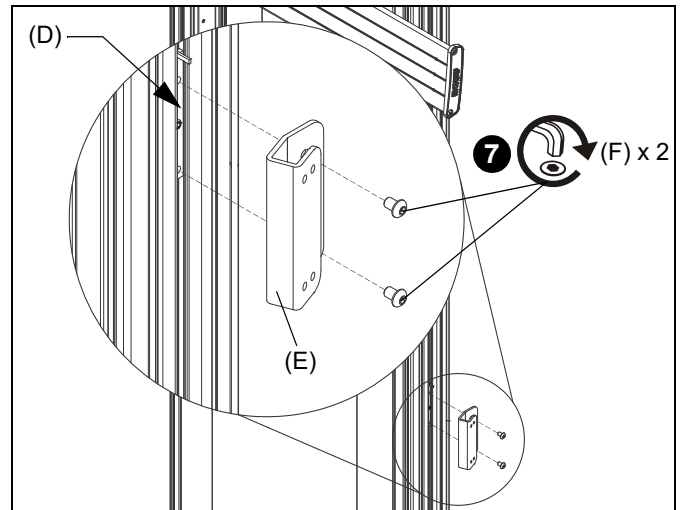

Figure 5

8. Loosely install 1/4-20 x 3/8" button head cap screw (F) into lower back hole on adapter bracket (E). (See Figure 6)
9. Loosely install 1/4-20 x 3/8" button head cap screw (F) through 1/4" washer (K) and into upper back hole on adapter bracket (E). (See Figure 6)

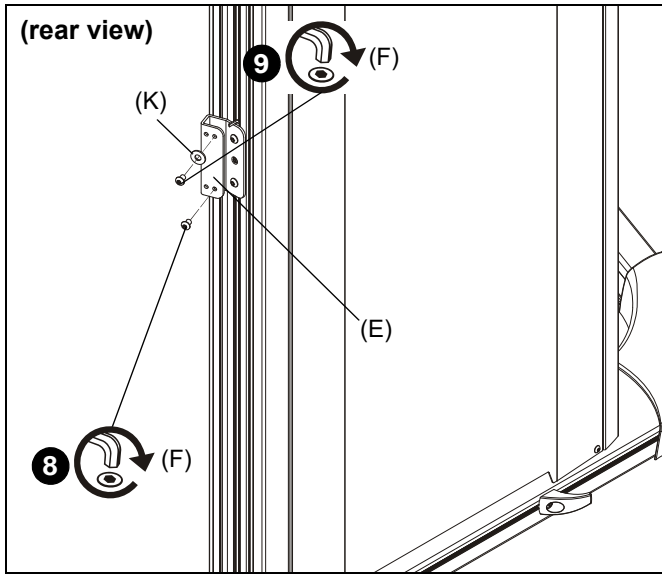

Figure 6

10. Hang shelf support (B or C) onto top screw installed in Step 6. (See Figure 5)
11. Tighten top screw to ensure shelf support is secured in position. (See Figure 7)

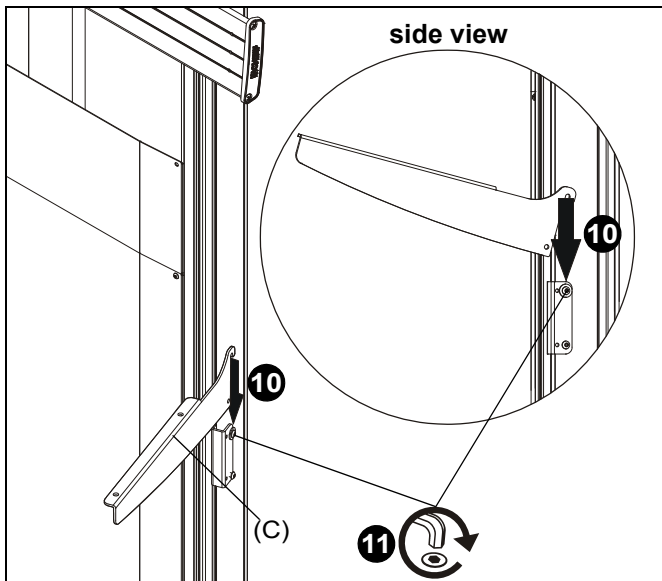

Figure 7

12. Install 1/4-20 x 3/8" button head cap screw (F) into lower front hole to secure shelf support (B or C) to adapter bracket (E). (See Figure 8)

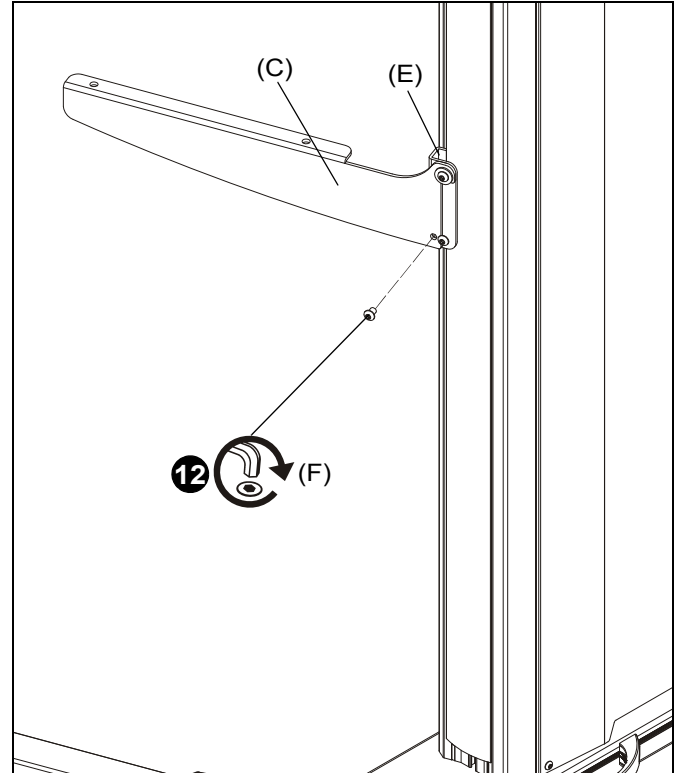

Figure 8

13. Repeat Steps 5-12 on other side of the cart with opposite shelf support.

**NOTE:** In order to ensure a level mount, measure the distance from the bottom of the cart to the shelf support and install the second shelf support at the same height.

14. Open storage tray lids and use four 1/4-20 x 1/2" button head cap screws (H) and four 1/4-20" lock nuts (J) to secure large storage shelf (A) to shelf supports (B and C). (See Figure 9) and (See Figure 10)

**NOTE:** The exact holes to use will depend on the model of the mounting system. Refer to Figure 9 to determine which holes to use.

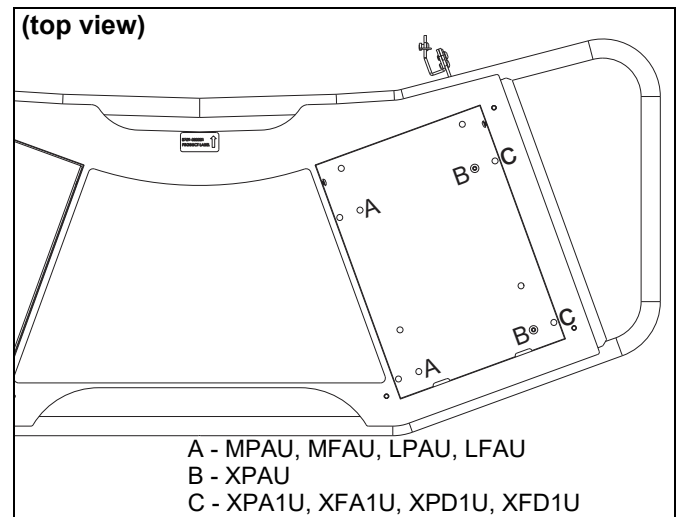

- A - MPAU, MFAU, LPAU, LFAU
- B - XPAU
- C - XPA1U, XFA1U, XPD1U, XFD1U

Figure 9

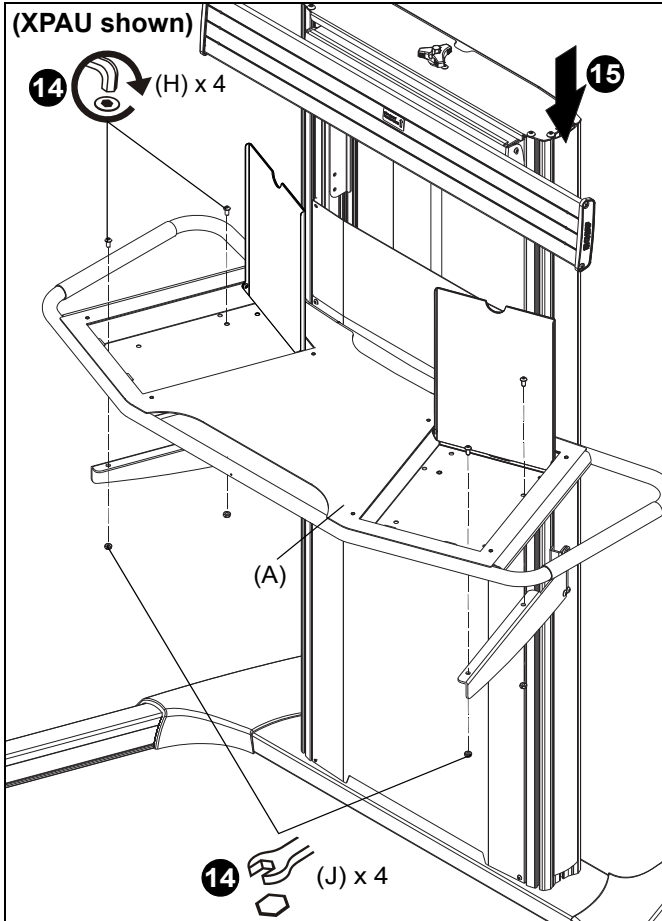

Figure 10

- 15. (XPD1U/XFD1U ONLY) Reinstall control pad bracket to side channel by reinstalling screw holding it to mount using 5/64" hex key (N). (See Figure 11)
- 16. (XPD1U/XFD1U ONLY) Reinstall control pad to control pad bracket. (See Figure 11)

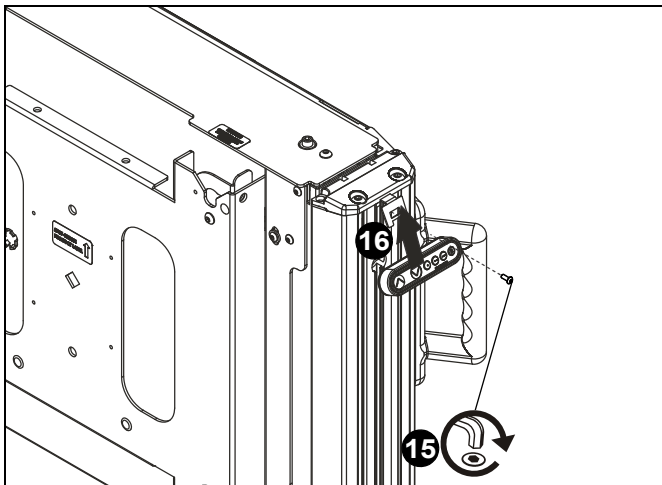

Figure 11

- 17. Reinstall side covers into each side of cart/stand. (See Figure 12)

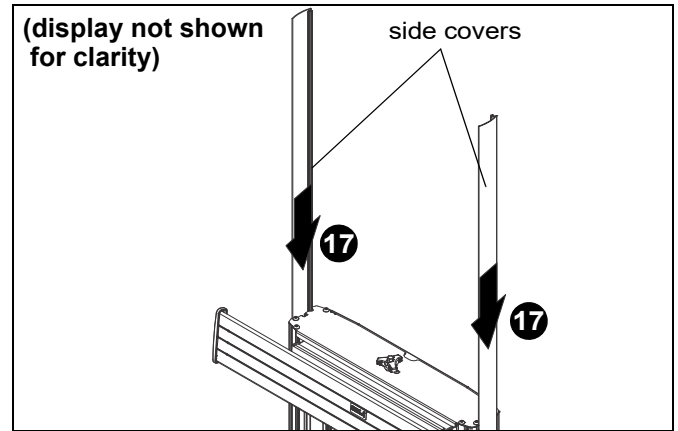

Figure 12

- 18. (XPD1U/XFD1U ONLY) Reinstall tabs from top of side channels using screws removed in Step 1. (See Figure 13)

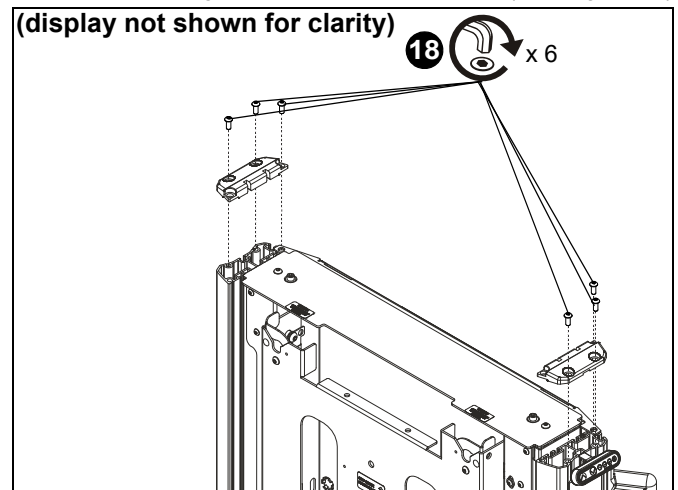

Figure 13

**IMPORTANT !** : On height-adjustable mounts (XPD1U/XFD1U), do NOT install shelf at a height where it could cause interference if the display is lowered. Shelf should be installed at a height that doesn't interfere when the display is at its lowest position. (See Figure 14)

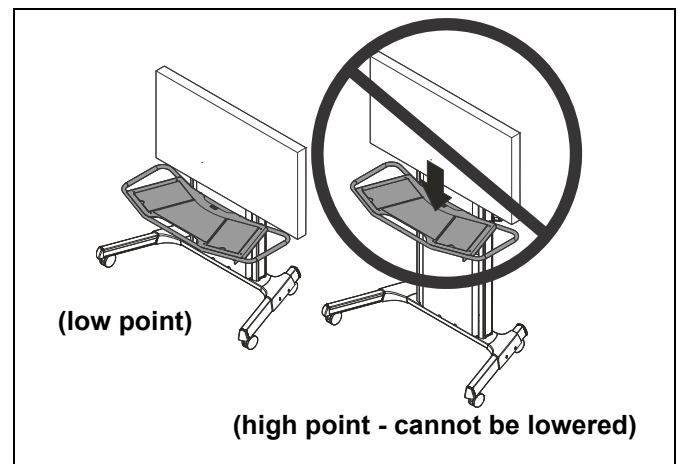

Figure 14



A brand of  **legrand**

8800-002882 Rev03  
©2021 Legrand | AV  
[www.legrandav.com](http://www.legrandav.com)  
06/21

<b>USA/International</b>	<b>A</b> 6436 City West Parkway, Eden Prairie, MN 55344 <b>P</b> 800.582.6480 / 952.225.6000 <b>F</b> 877.894.6918 / 952.894.6918
<b>Europe</b>	<b>A</b> Franklinstraat 14, 6003 DK Weert, Netherlands <b>P</b> +31 (0) 495 580 852 <b>F</b> +31 (0) 495 580 845
<b>Asia Pacific</b>	<b>A</b> Office No. 918 on 9/F, Shatin Galleria 18-24 Shan Mei Street Fotan, Shatin, Hong Kong <b>P</b> 852 2145 4099 <b>F</b> 852 2145 4477

