

# COMPACT ELECTROL

Motorized projection screen for wall or ceiling installations

**DA-LITE**  
A brand of **legrand**

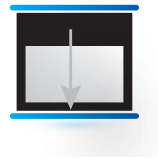

## Product specifications:

- Electrically operated projection screen 230 volt (50Hz) with a usage of no more than 0.43 Ampere (98.9 Watt).
- The motor is mounted on the left side in the steel casing.
- The motor is mounted inside the roller, 4 wire, 28 rotations per minute, maintenance free, integrated brake and thermal overload cut-out.
- The 4 wire connection is integrated into the end cap and can be connected to the electric installation with the connector and standard cable.
- Suitable for wall and ceiling mounting with the supplied flexible mounting brackets (50cm).
- The steel square casing (8,8x8,8cm) is galvanised on the inside and on the outside powder coated with a matte structure coating (RAL 9016).
- The grey end caps close the casing on both ends. The triangular slat bar closes of the bottom of the casing completely.
- The screen fabrics are flame retardant and seamless.
- The projection fabrics have a 5 cm. border all around with the Video, HDTV, and Wide format. The standard format (1:1) has a black border on both sides (width  $\leq 240\text{cm} = 2.5\text{cm}$  and  $> 240\text{cm} = 5\text{cm}$ ).
- The projection fabrics have a black backing.
- Standard 3 position wall switch is supplied.
- The projection screen is CE marked and satisfies the strictest quality and safety requirements.
- Integrated RF receiver option: this version will have a 3 wire connection and will be supplied with a remote control.

## Options:

- RF - Radio frequency: Includes built-in radio frequency receiver, making it possible to operate the screen using the supplied remote control. Standard remote control is supplied when selected this option.
- Extended black drop
- Without borders



## Available dimensions

Minimum width: 160 cm  
Maximum width: 300 cm

## Aspect Ratios:

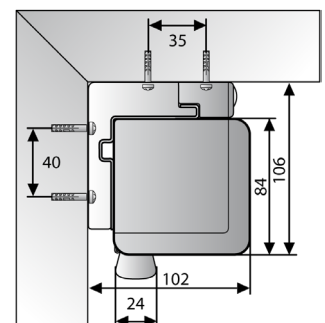

# COMPACT ELECTROL

**DA-LITE**  
A brand of **Legrand**

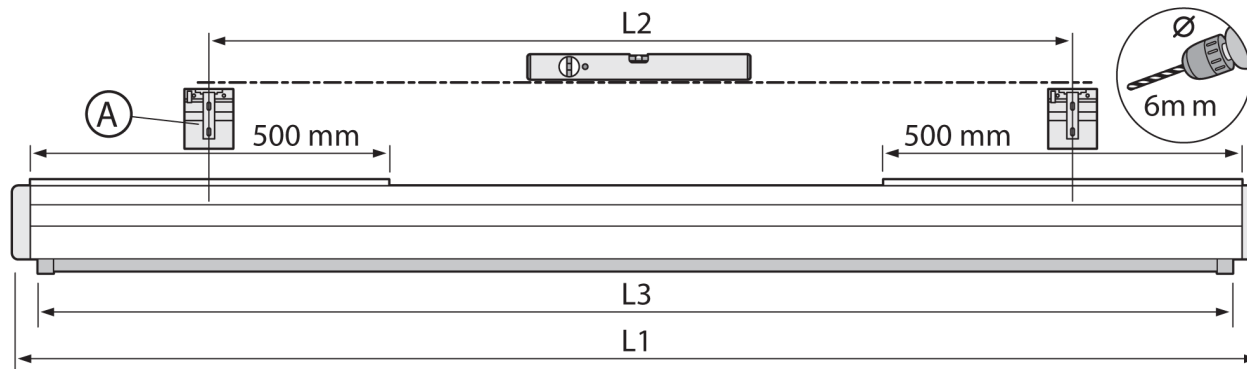

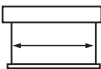
		Viewing Area	Dimensions			Border	Net weight
		cm	L1 mm	L2 mm	L3 mm	cm	kg
<b>16:10</b>	129 x 200	119 x 190	2134	1754	2040	5	14
	141 x 220	131 x 210	2334	1954	2240	5	16
	154 x 240	144 x 230	2534	2354	2440	5	18
	179 x 280	169 x 270	2934	2754	2840	5	22
	191 x 300	181 x 290	3134	2954	3040	5	24
<b>16:9</b>	90 x 160	82 x 146	1714	1534	1620	5	10
	102 x 180	95 x 168	1914	1734	1820	5	12
	117 x 200	107 x 190	2134	1754	2040	5	14
	128 x 220	118 x 210	2334	1954	2240	5	16
	139 x 240	129 x 230	2534	2354	2440	5	18
	162 x 280	152 x 270	2934	2754	2840	5	22
	173 x 300	163 x 290	3134	2954	3040	5	24
<b>4:3</b>	123 x 160	110 x 146	1714	1534	1620	5	10
	138 x 180	126 x 168	1914	1734	1820	5	12
	153 x 200	143 x 190	2134	1754	2040	5	14
	168 x 220	158 x 210	2334	1954	2240	5	16
	183 x 240	173 x 230	2534	2354	2440	5	18
	213 x 280	203 x 270	2934	2754	2840	5	22
	228 x 300	218 x 290	3134	2954	3040	5	24
<b>1:1</b>	160 x 160	151 x 151	1714	1534	1620	2,5 L/R	10
	180 x 180	173 x 173	1914	1734	1820	2,5 L/R	12
	200 x 200	195 x 195	2134	1754	2040	2,5 L/R	14
	220 x 220	215 x 215	2334	1954	2240	2,5 L/R	16
	240 x 240	230 x 230	2534	2354	2440	2,5 L/R	18

# COMPACT ELECTROL

Available standard resolution projection surfaces  
All screen surfaces are seamless in the viewing area.

## Matte White

Gain: 1.0  
Viewing Angle: 120°  
Base material: Fiberglass  
Fire retardancy: B2  
Black backing: Yes  
Opacity rating: > 99 %  
Seamless: Yes  
GreenGuard certification: Yes



Standard: UL 2818 - 2013 Standard for Chemical Emissions for Building Materials, Finishes and Furnishings

Certification number

Greenguard - 4710-410

Greenguard Gold - 4710-420

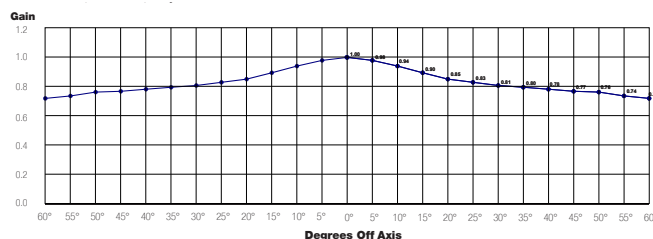

## High Contrast

Gain: 1.1  
Viewing Angle: 100°  
Base material: Fiberglass  
Fire retardancy: B2  
Black backing: Yes  
Opacity rating: > 99 %  
Seamless: Yes  
GreenGuard certification: Yes



Standard: UL 2818 - 2013 Standard for Chemical Emissions for Building Materials, Finishes and Furnishings

Certification number

Greenguard - 4708-410

Greenguard Gold - 4708-420

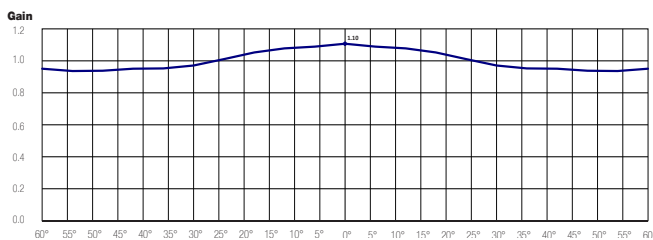

## Certifications

- Products are manufactured in an ISO14001 certified facility
- Projecta is an ISO 9001 certified company
- REACH - Registration, Evaluation, Authorisation and Restriction of Chemical substances.
- RoHS - Restriction of Hazardous Substances.
- WEEE - Waste Electronic and Electrical Equipment Regulations.



## Customisation

Give exact the sizes of the projection screen you need:

Viewing size: \_\_\_\_\_ Height (cm.) x \_\_\_\_\_ width (cm.)

Surface: \_\_\_\_\_ Border top: \_\_\_\_\_ (cm.) Border bottom: \_\_\_\_\_ (cm.)

RAL color case and plastic parts: RAL \_\_\_\_\_

Screen fabric mounted reversely

Remarks: \_\_\_\_\_

## Accessories - control options

For projection screens with a standard motor / delivered as standard with a wall switch

- Easy Install RF remote control (868,3 Mhz)
  - Easy Install wireless projectorcoupling (868,3 Mhz)
  - Easy Install wireless RF wall switch (868,3 Mhz)
- Easy Install RF remote control with projectorcoupling (868,3 Mhz)
- Easy Install projectorcoupling with cable
- Easy Install IR remote control
- Easy Install plug & play relaybox with potential free contacts
  - Easy Install plug & play RS232/RS422 control kit
  - Easy Install plug & play RS232/RS422 with IP control kit
- Keyswitch

For projection screens with an RF motor / delivered as standard with a remote control

- RF wall-mounted transmitter (433,92 Mhz)
- 4-channel RF remote control (433,92 Mhz)
- Easy Install plug & play connector cable for RF screens 10 m
- Easy Install plug & play connector cable for RF screens 5 m

## Accessories - installation

- Ceiling brackets (100 cm.)
- Set extension brackets (75 cm.)
- Set extension brackets (30 cm.)
- Set extension brackets (10 cm.)
- Wall clamps
- Bracket kit for easy mounting in soffit

## Compact Electrol - mounting bracket included

(Dimensions in mm)

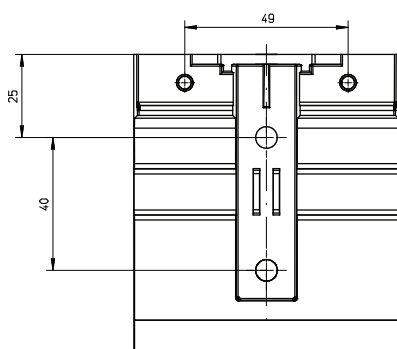
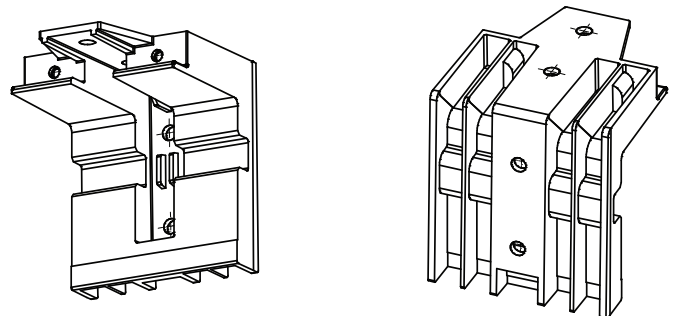

front view

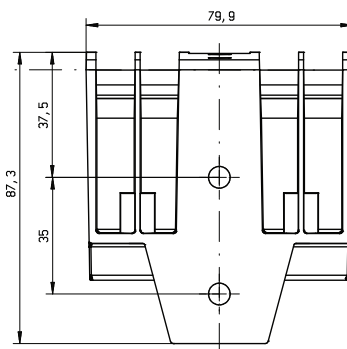

top view

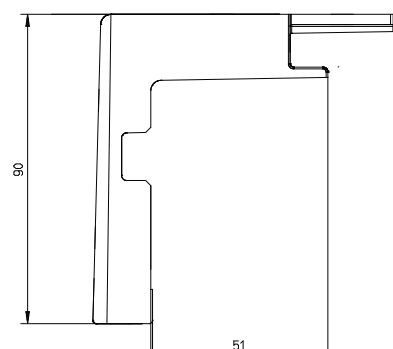

side view

## Warranty

Da-Lite provides a limited 5 year warranty on the Elpro Concept range and a limited 2 year warranty on all other products. The warranty on the motor of electrical screens is 5 year. All warranties are in effect beginning the date the product was invoiced by Da-Lite.