

Sprinter DS +
DisplayShift²
4031000503

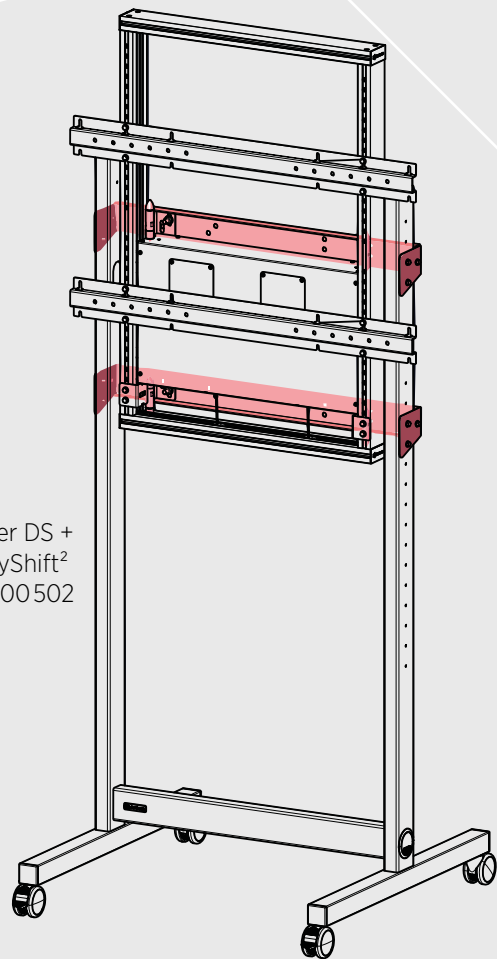

Sprinter DS +
DisplayShift²
4031000502

Montageanleitung | Mounting instructions

Montageset | Mounting brackets DisplayShift²/Sprinter DS

Passend für DisplayShift² 4031000502/503 mit Sprinter DS 4004000200
Suitable for DisplayShift² 4031000502/503 with Sprinter DS 4004000200

Inhaltsverzeichnis

1. Grundlegende Sicherheitshinweise	3
2. Montageanleitung	4
2.1 Lieferumfang	5
2.2 Benötigtes Werkzeug	5
2.3 Montage	6
3. Abmessungen	10
4. Spezifikationen	11

Table of contents

1. Basic safety instructions	3
2. Mounting instruction.....	4
2.1 Scope of delivery	5
2.2 Required tools	5
2.3 Assembling	6
3. Dimensions	10
4. Specifications	11

1. Sicherheitshinweise - Safety instructions

Achtung

- Bitte diese Anleitung sorgfältig durchlesen und aufbewahren.
- Die Montage des Adaptersets darf nur durch qualifiziertes Personal erfolgen.
- Das Adapterset darf nur mit dem Displayständer Sprinter DS 4004 000 200 und den beiden DisplayShift-Modellen 4031 000 502 und 4031 000 503 kombiniert werden.
- Die Gesamtkonstruktion darf ausschließlich zur Montage von geeigneten Flachbild-Monitoren, in geschlossenen, geraden, ebenen und trockenen Räumen verwendet werden.
- Bitte beachten Sie die Montage und Nutzungshinweise aus den Anleitungen für den Rollständer Sprinter DS und der Höhenverstellung DisplayShift².
- Achten Sie bei der Montage darauf, die Schrauben nicht zu überdrehen und dadurch das Gewinde zu beschädigen. Ein defektes Gewinde darf nicht zur Montage verwendet werden!

Attention

- Please read these instructions carefully and keep them in a safe place.
- The adapter set may only be installed by qualified personnel.
- The adapter set may only be combined with the display stand Sprinter DS 4004 000 200 and the two DisplayShift models 4031 000 502 and 4031 000 503.
- The entire product may only be used for mounting suitable flat screen monitors, in closed, straight, level and dry rooms. The display weight must be selected according to the two DisplayShift types.
- Please note the mounting and operation instructions of the mobile stand Sprinter DS and DisplayShift² height adjustable system.
- During assembly, take care not to overtighten the screws and thereby damage the thread. A defective thread must not be used for assembly!

2. Montageanleitung – Mounting instructions

Art.-Nr./Ref.No. 4004 000 203

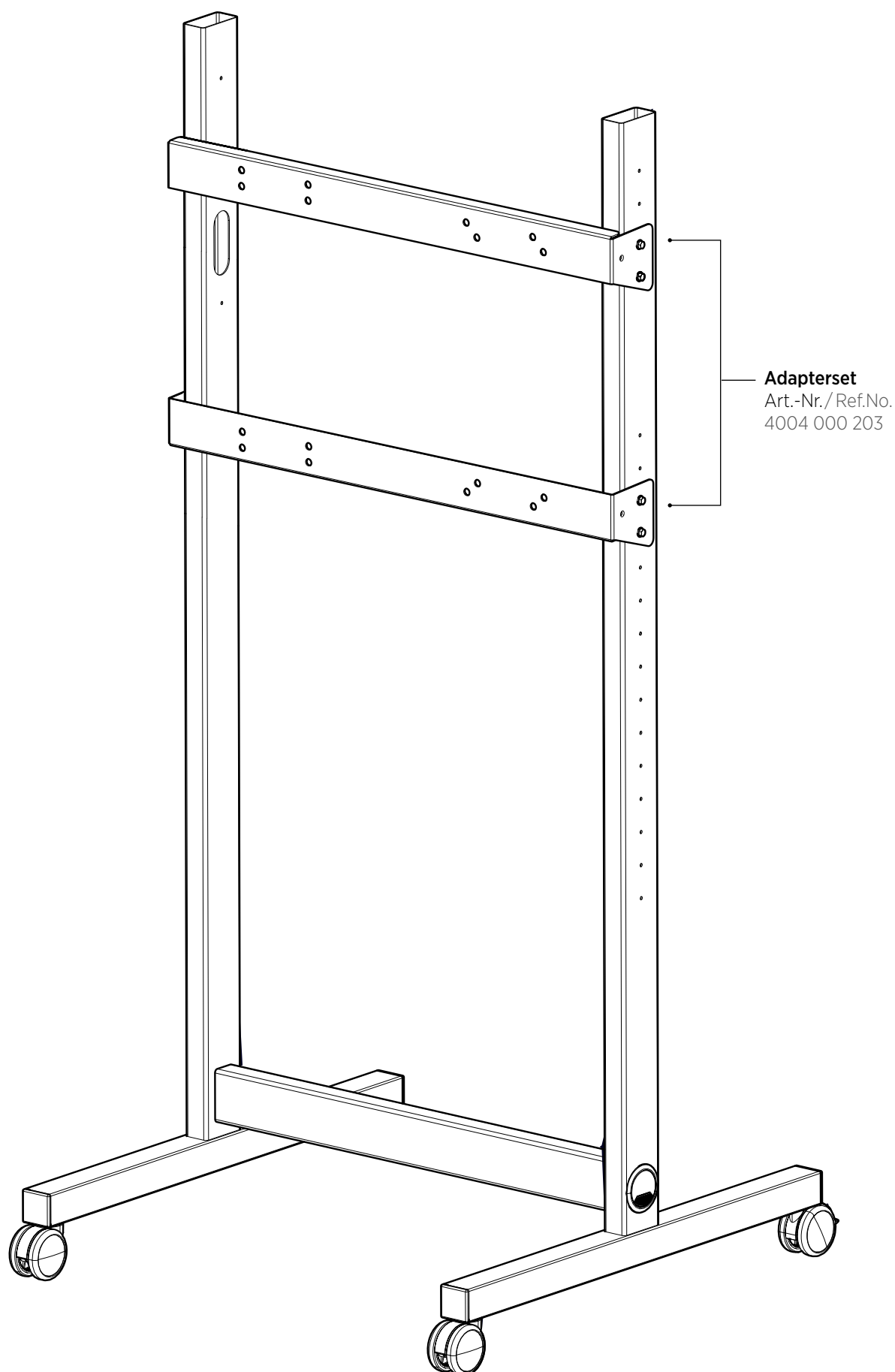

2.1 Lieferumfang – Scope of delivery

Art.-Nr./ Ref.No. 4004 000 203

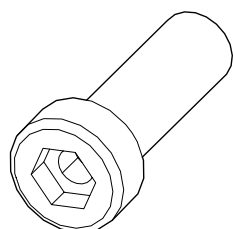
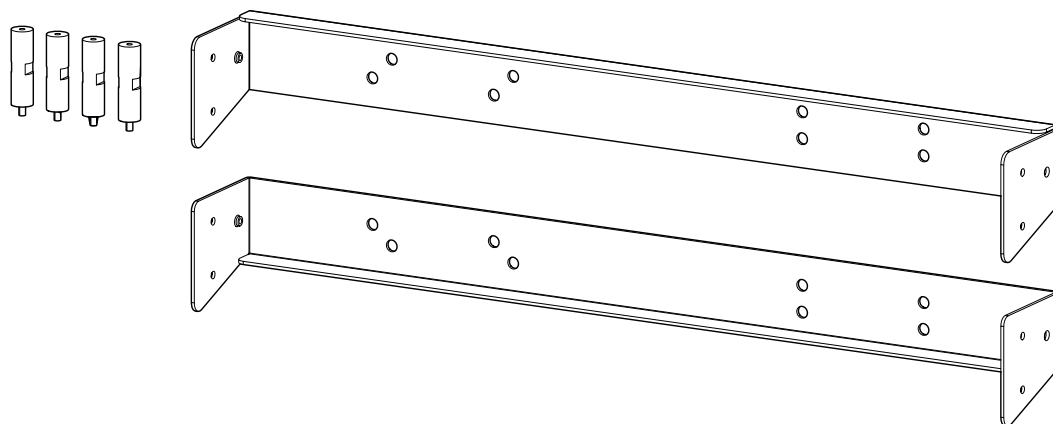

4 x M10x25

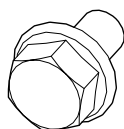

8 x M6x10

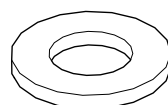

4 x 10,5

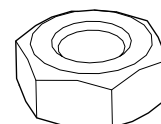

4 x M10

2.2 Benötigtes Werkzeug – Required tools



3, 8



10, 14, 17

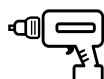

2.3 Montage – Assembling

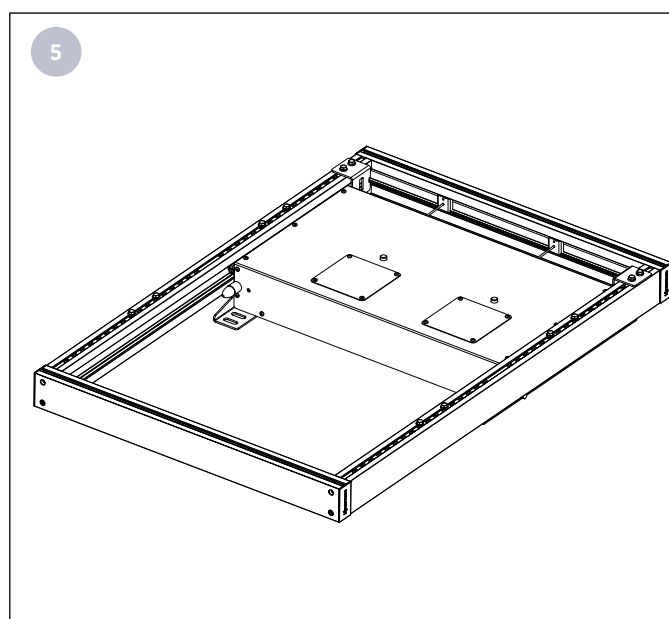
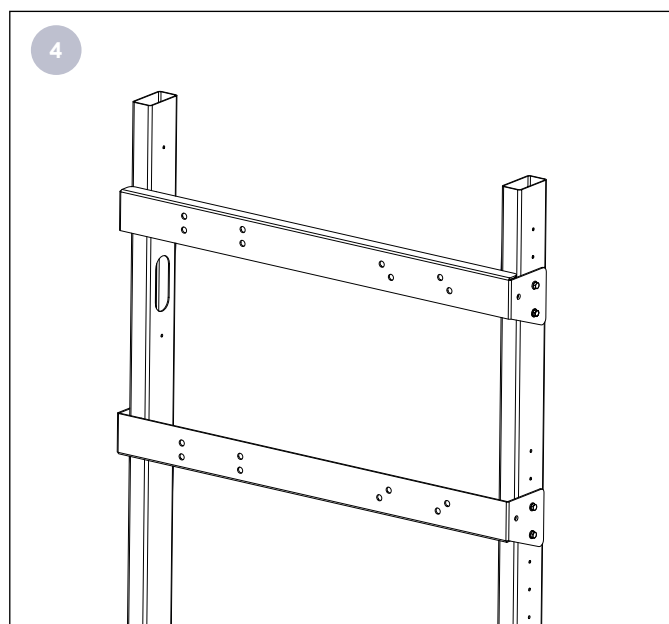
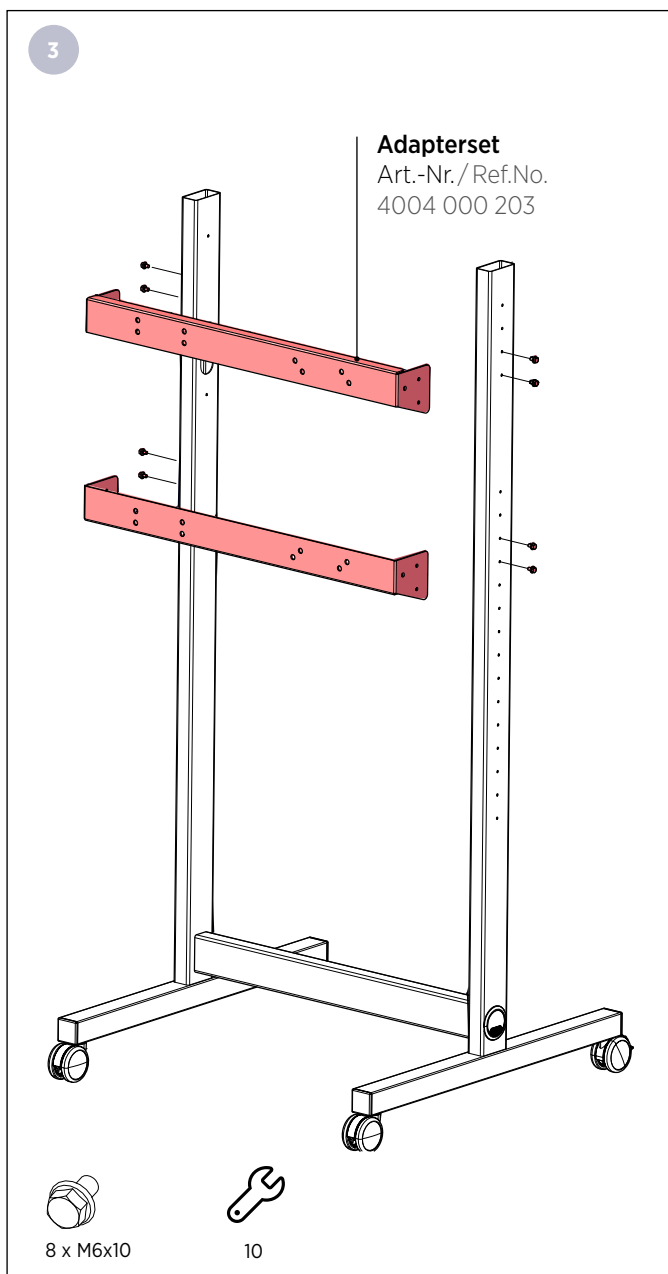
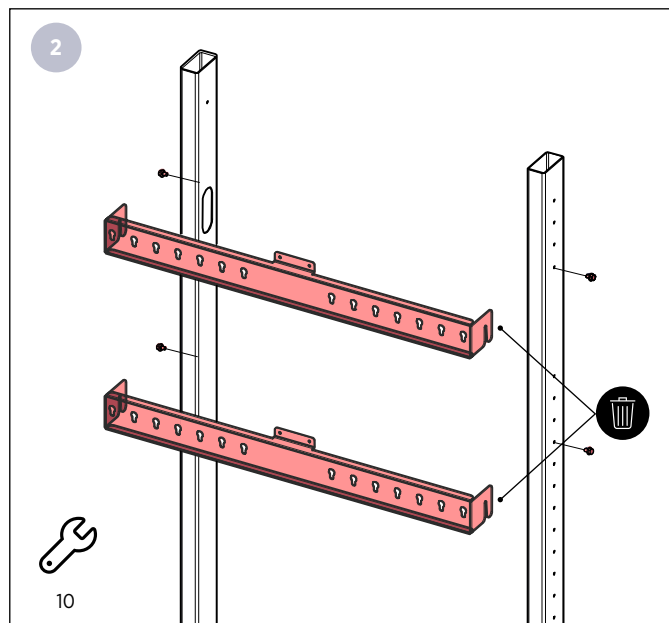
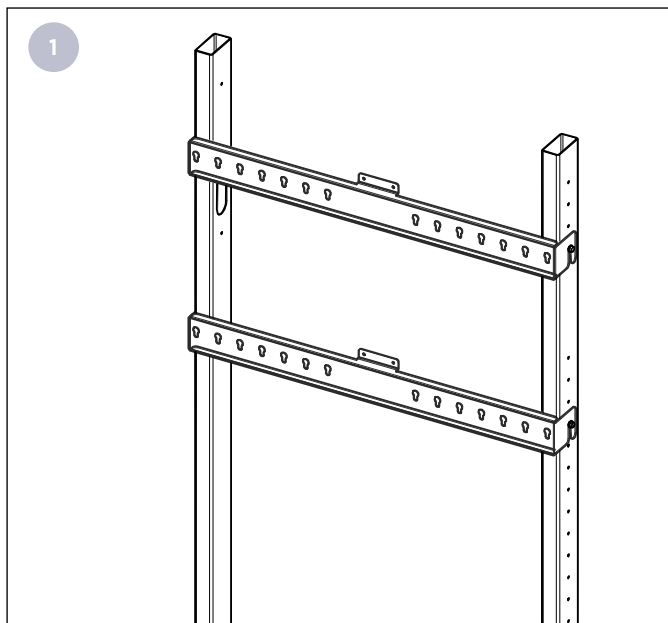

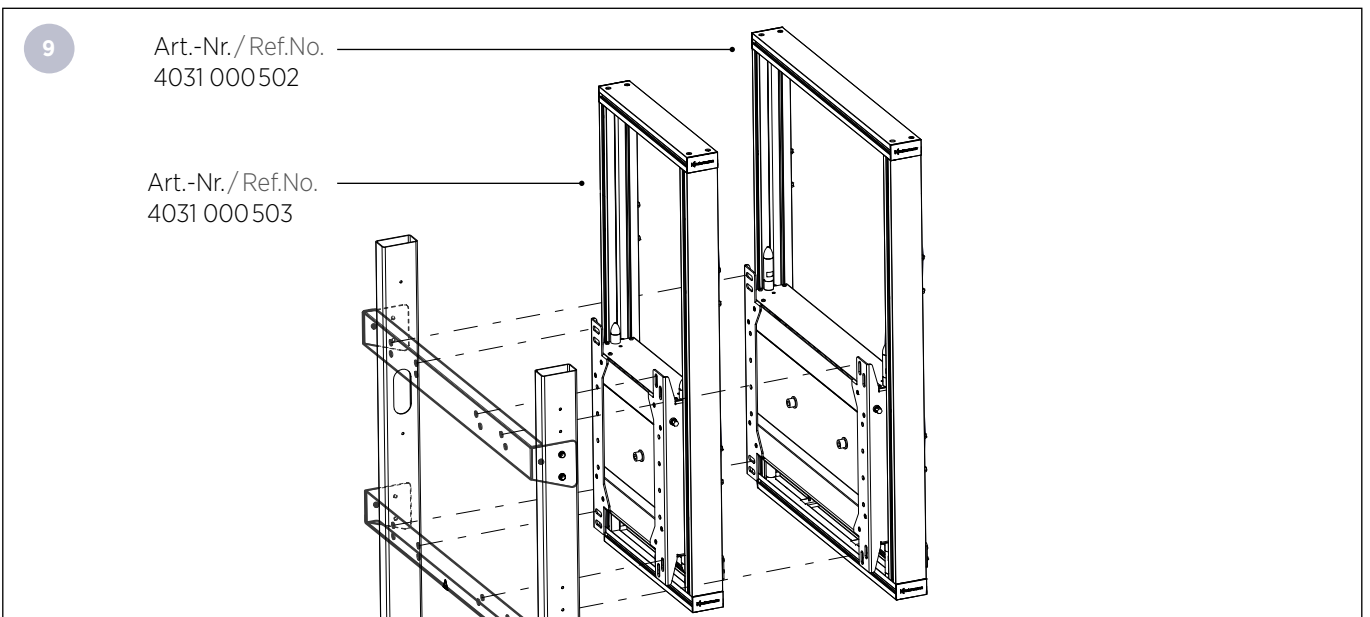
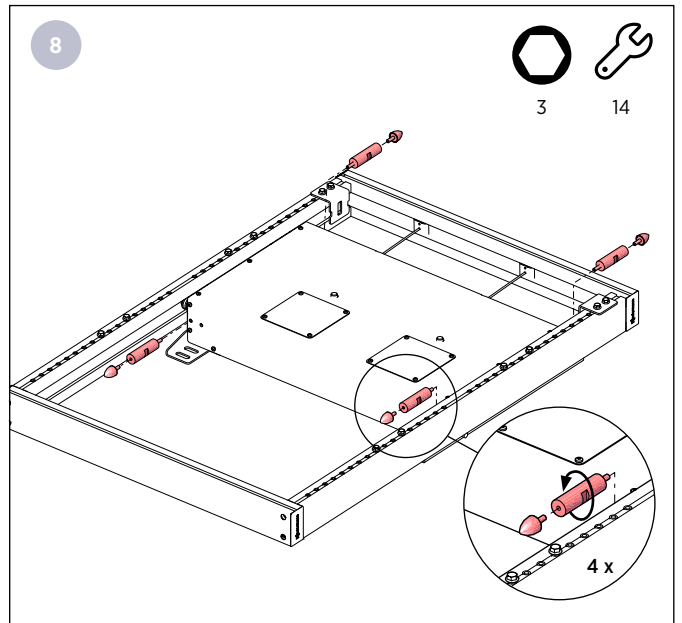
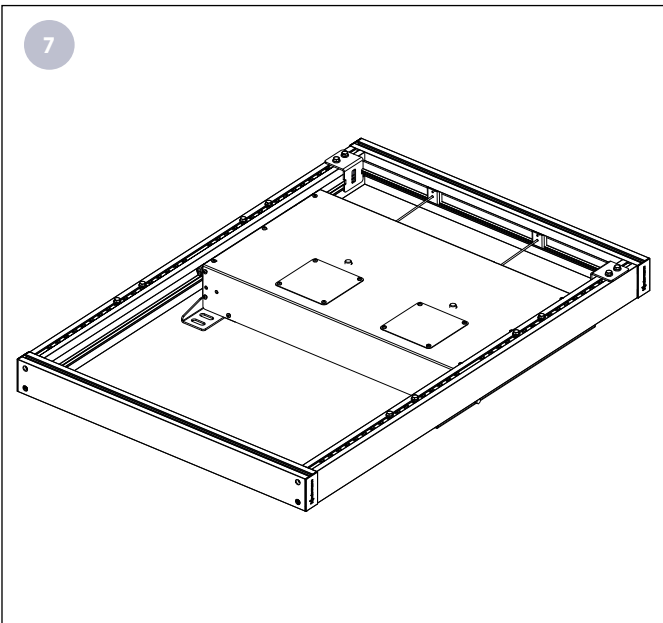
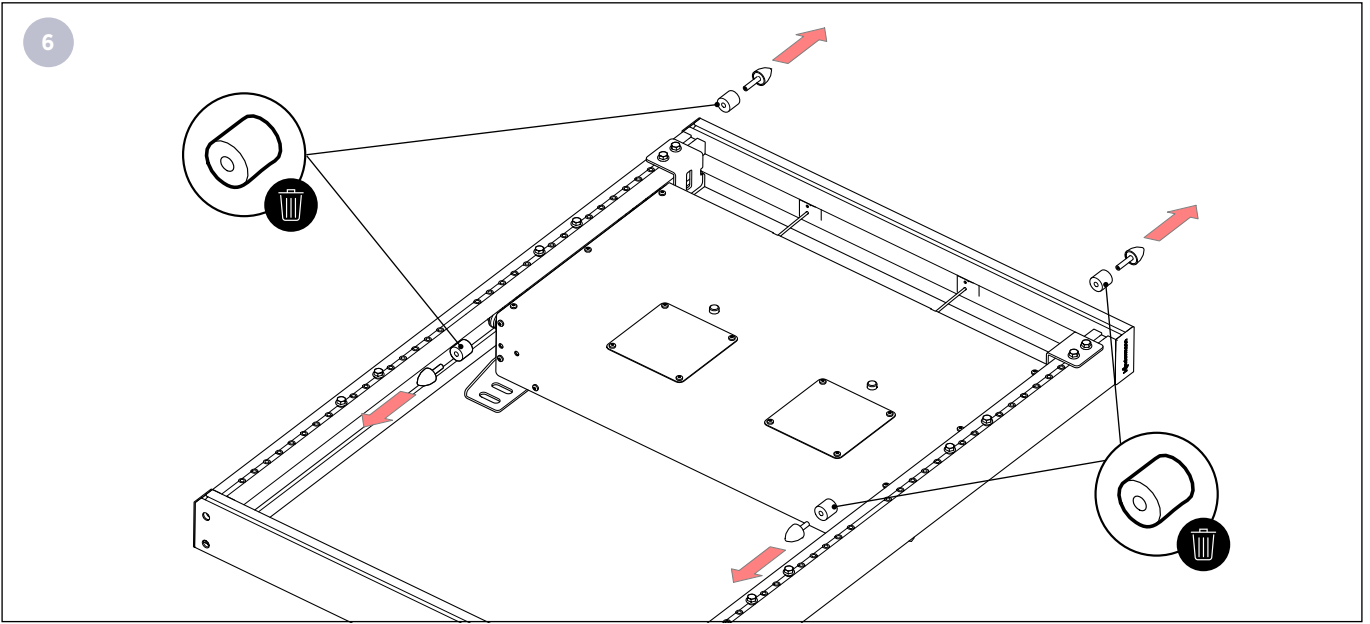

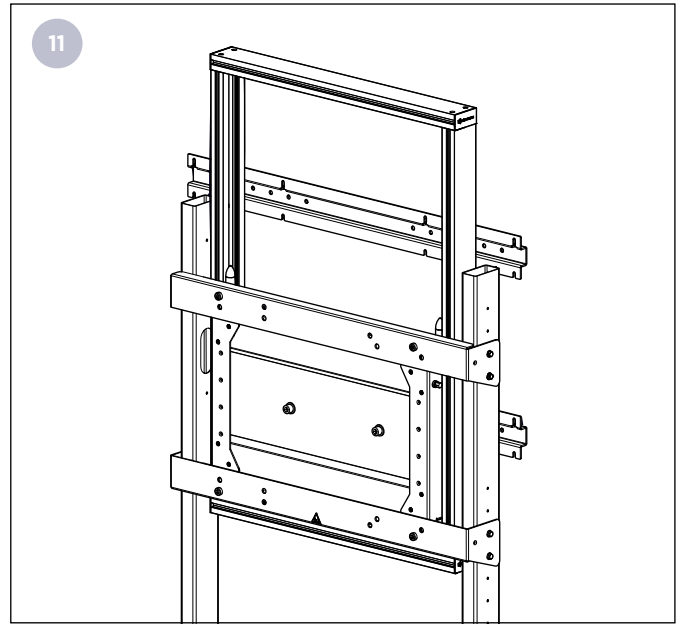
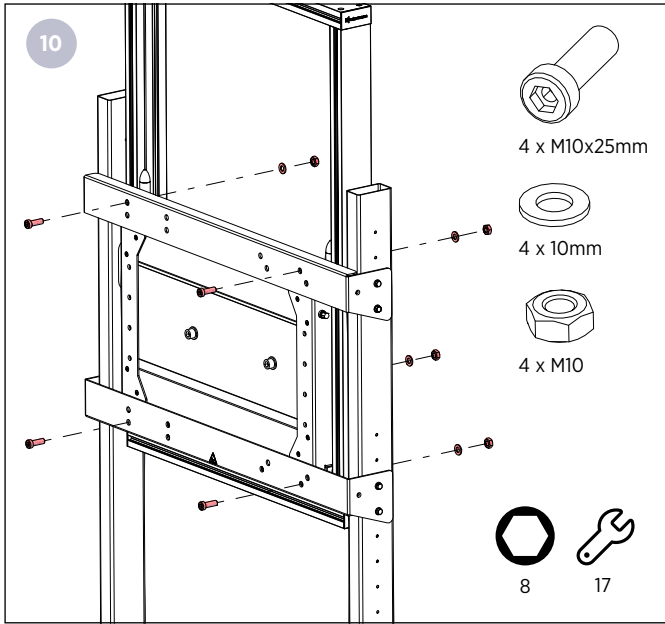

12

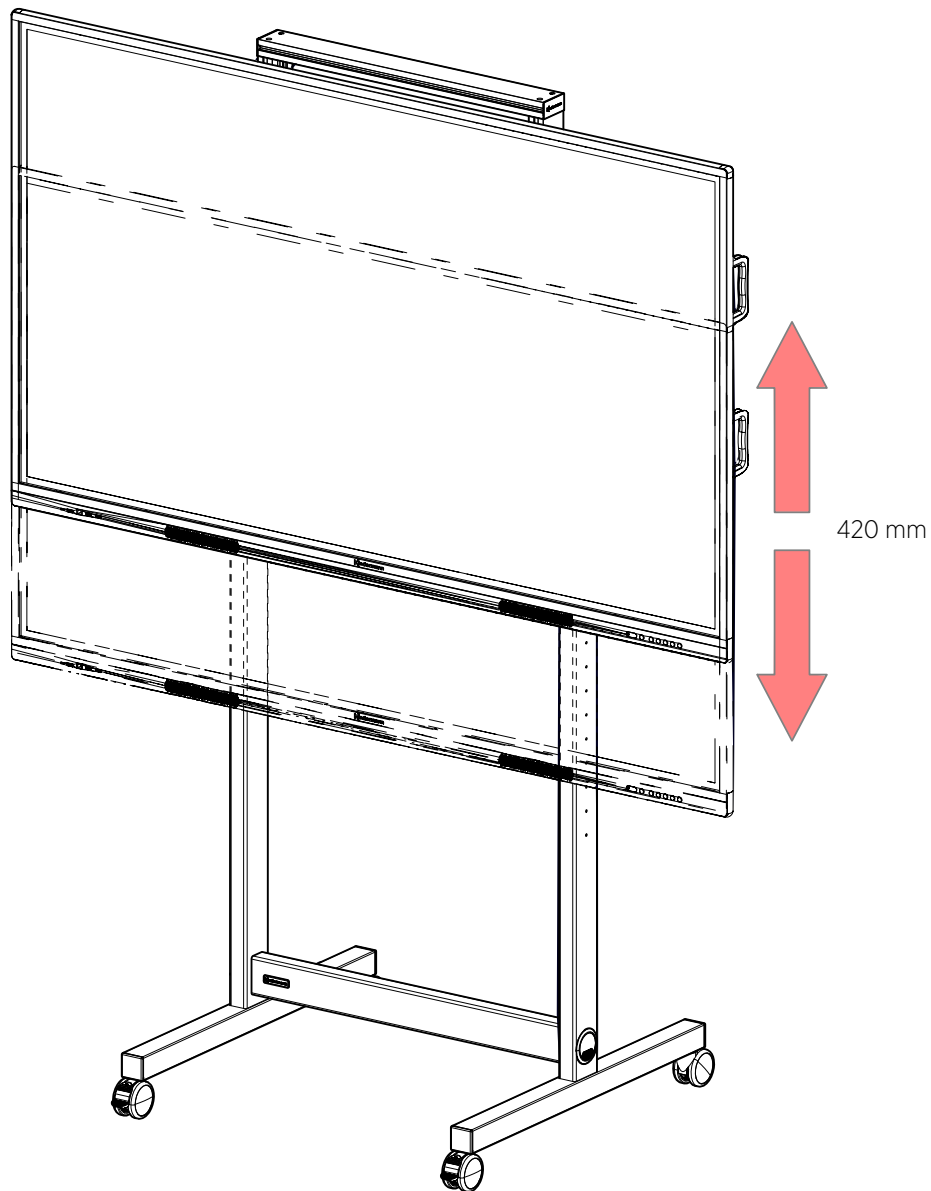

3. Abmessungen - Dimensions

Art.-Nr./Ref.No.
4004 000 203 + 4031 000 503 + 4004 000 200

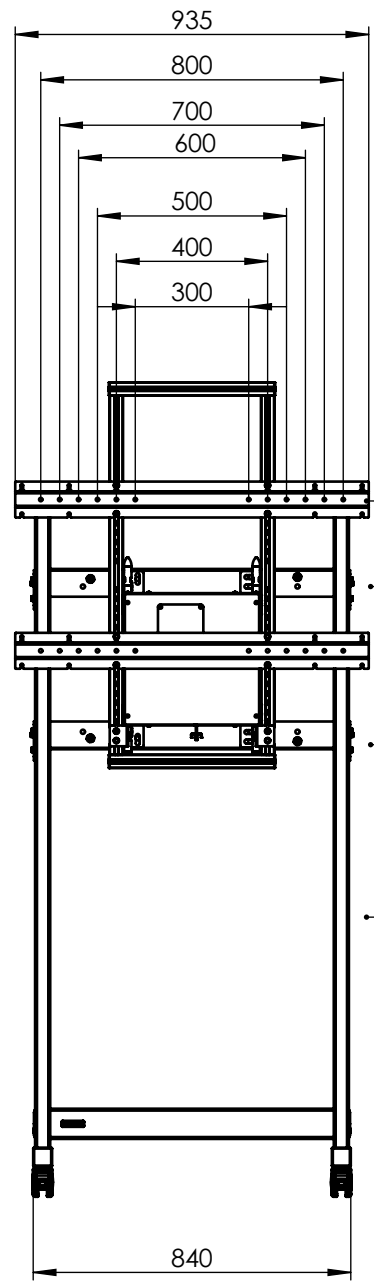
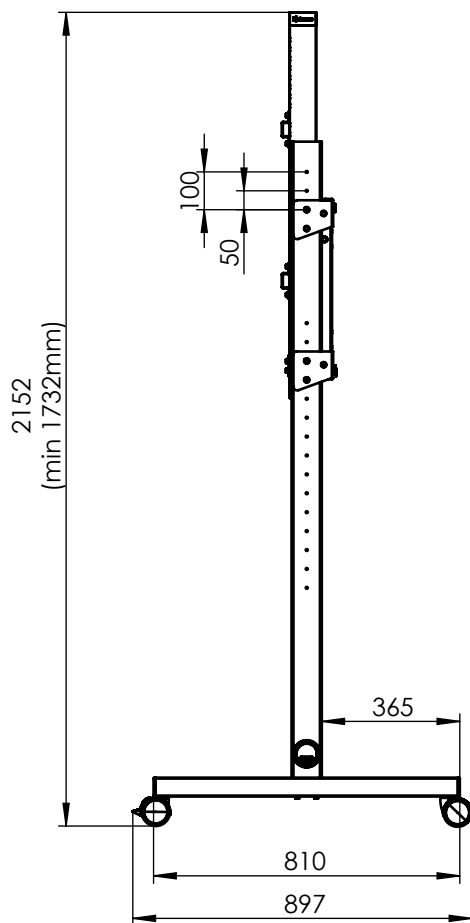

DisplayShift²
Art.-Nr./Ref.No.
4031 000 503

Adapterset
Art.-Nr./Ref.No.
4004 000 203

Sprinter DS
Art.-Nr./Ref.No.
4004 000 200

Art.-Nr./Ref.No.
4004 000 203 + 4031 000 502 + 4004 000 200

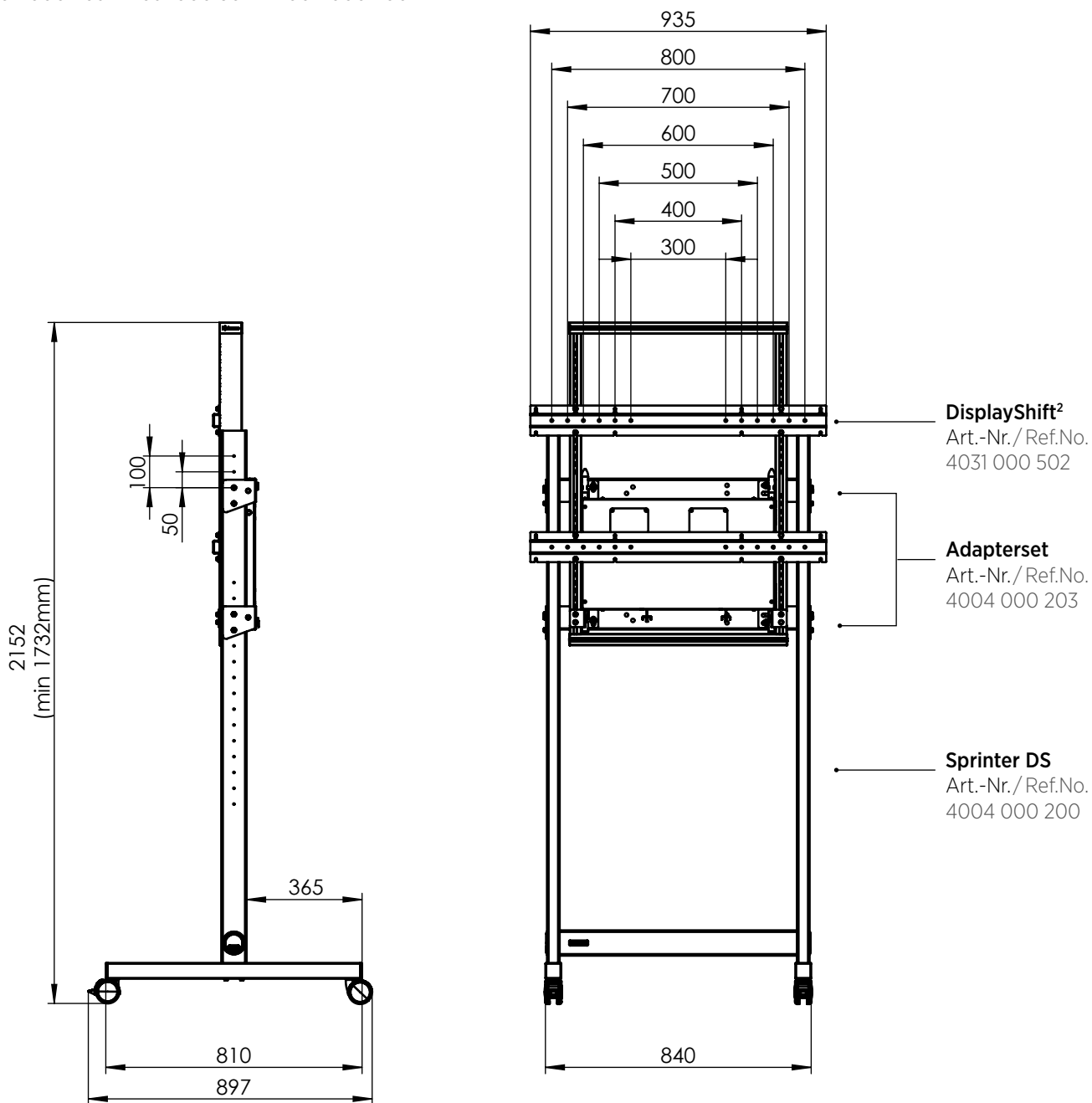

4. Spezifikationen – Specifications

Art.-Nr./ Ref.No. 4004 000 203	
Abmessungen ohne Display (BxHxT) Dimensions without display (WxHxD)	837 x 105 x 103
Gewicht ohne Display Weight without display	2 x 2,4 kg
Material – Farbe/ Material - colour	Stahl, gepulvert schwarz/ steel, powdered black

5. Service/Support – Service/Support

Technische Fragen / Technical issues: [**support@kindermann.de**](mailto:support@kindermann.de)

Reparaturrückfragen, Reklamationsbearbeitung, Ersatzteilbestellung /
Questions regarding pending repairs, claims, spare parts: [**service@kindermann.de**](mailto:service@kindermann.de)

Kindermann GmbH

Mainparkring 3 | D-97246 Eibelstadt | Germany

Email: info@kindermann.de

Änderungen vorbehalten | Subject to alterations | 4004 000203 | 842 236 | DE/EN | 10.2023

[**www.kindermann.com**](http://www.kindermann.com)