



Contents

- LED display cabinet x 5 pcs
 - Power supply box
 - Modular Meeting Room box & accessories
 - Quick start guide
 - Crossbeam x 2 pcs
 - Bottom sound bar
 - Edge finishing frames (Left & Right & Top frame)
 - Front panel of bottom sound bar x 3 pcs
 - Rail mounting plate x 2 pcs
 - Fixture x 2 pcs
 - Power cord**
 - CRD22 Wifi module
 - Infrared Remote Control
 - Floor stand & back cover plate (optional item)
- (Optional Independent packaging)*

* Floor stand & back cover plate are optional and exclusive to the Pedestal Mounted version

** Differences according to regions.
Display design and accessories may differ from those illustrated Above.



1-1 Installation

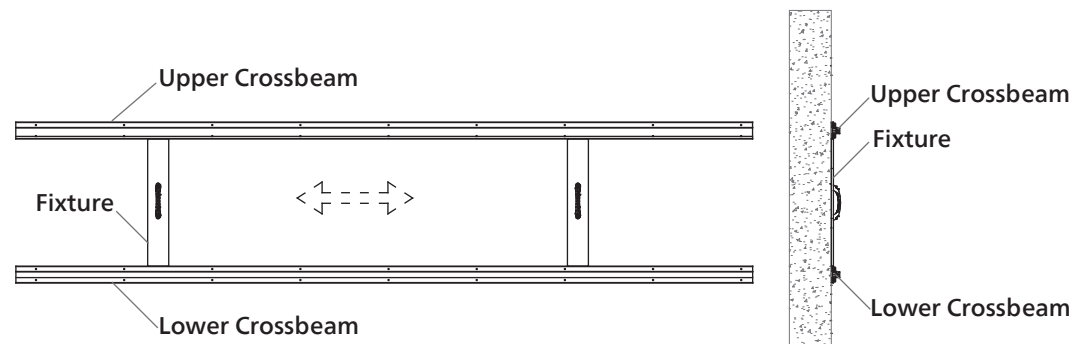

Wall Mounted Version:
The fixtures are used to adjust the level of the beam,
Install the lower crossbeam first.
Use two fixtures to locate and install the upper crossbeam,
and remove them after use.

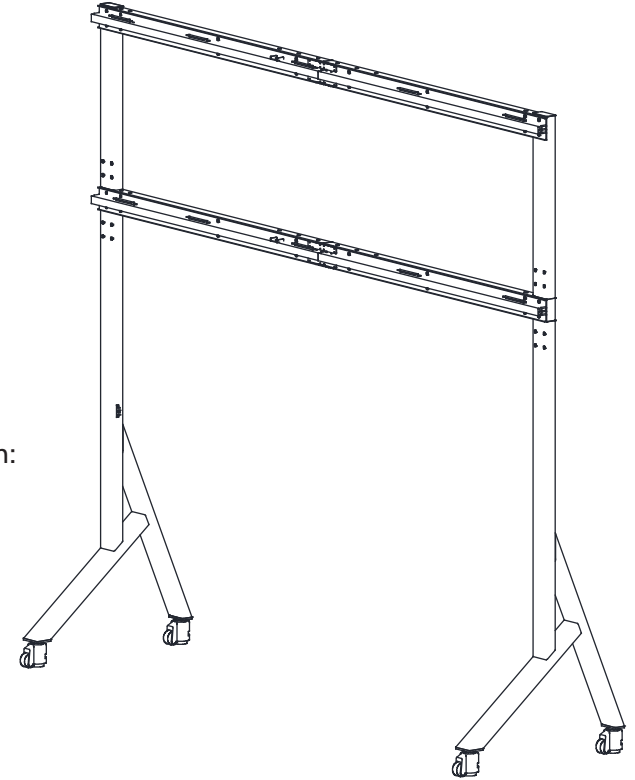
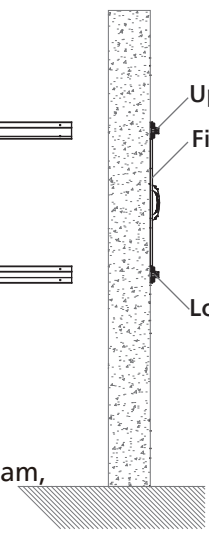

Pedestal Mounted Version:
1. Install the Floor Stand*
2. Install the Crossbeams

1-2 Installation

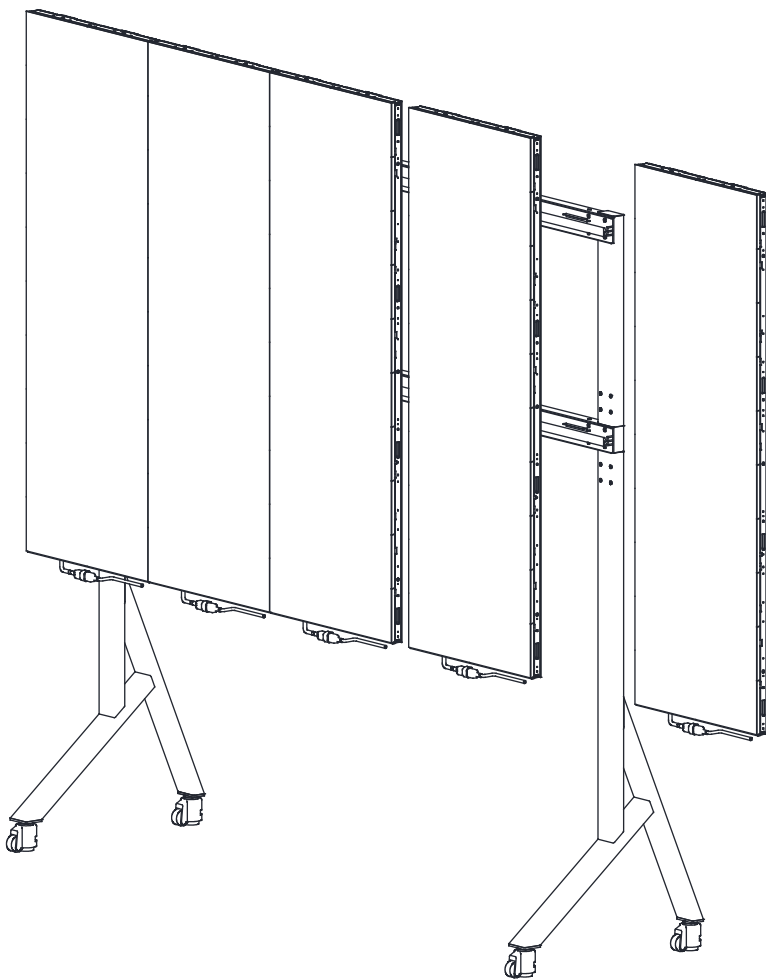

Install the Cabinets on the pedestal* or wall mounted.
Use the HEX screwdriver to lock the column cabinets in sequence
through the quick locks.

1-3 Installation

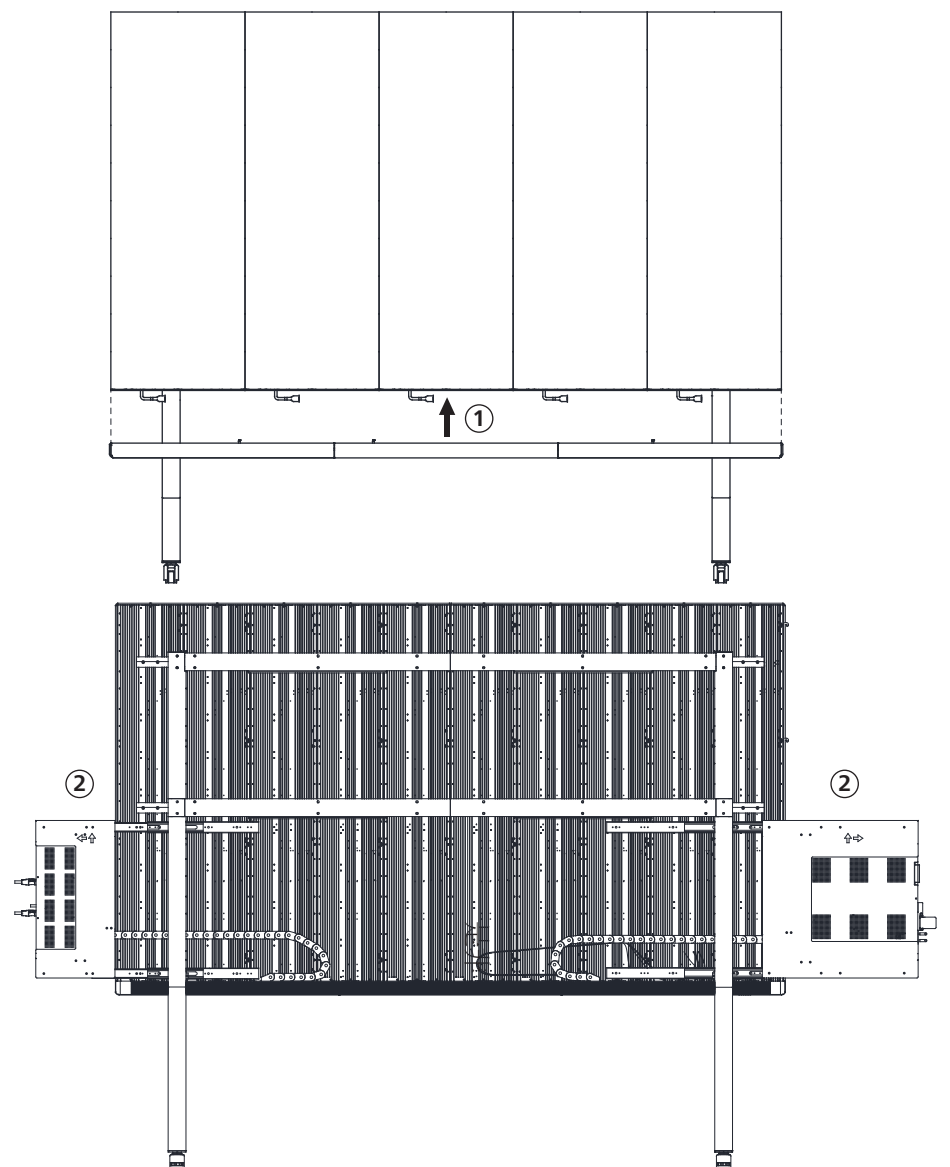
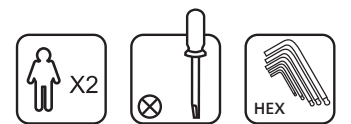

1. Install the Bottom sound bar
2. Install the Modular Meeting Room box & Power supply box
3. Connect the cables

1-4 Installation

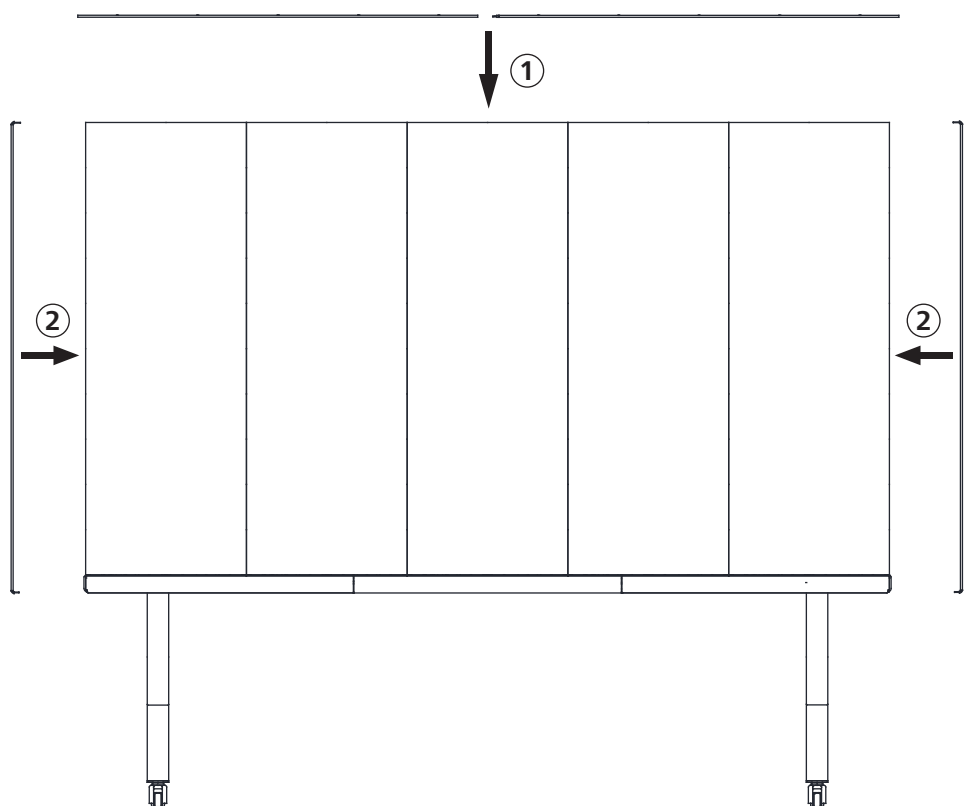
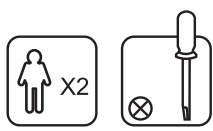

Install the Edge finishing frames (Left & Right & Top frame)

PHILIPS

Unite LED Display

5000 Series

135HDL5015IA



Quick start



For more information, please visit:
<https://www.philips.com/ppds>

1-5 Installation

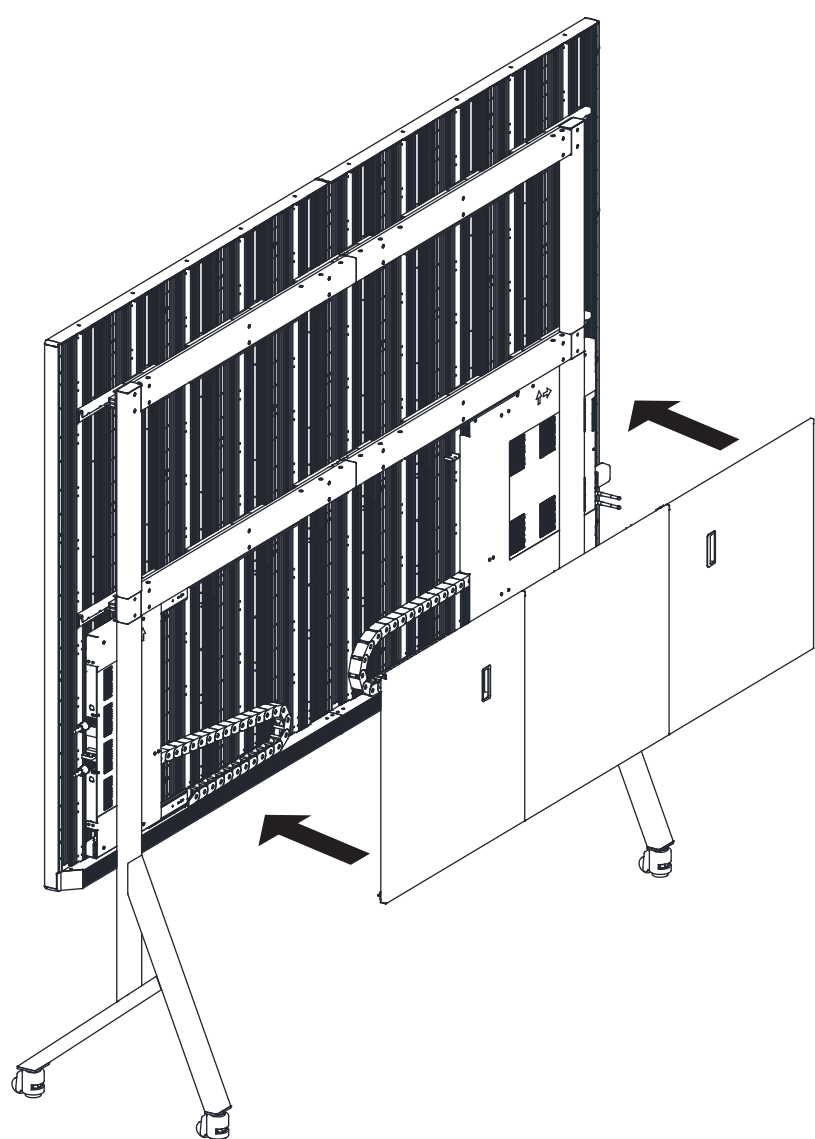

Install the optional Back Cover Plate*



Version: V1.00 2024-04-07

2024 © TOP Victory Investments Ltd. All rights reserved.

This product has been manufactured by and is sold under the responsibility of Top Victory Investments Ltd., and Top Victory Investments Ltd. is the warrantor in relation to this product. Philips and the Philips Shield Emblem are registered trademarks of Koninklijke Philips N.V. and are used under license.

Specifications are subject to change without notice.