

Area		JAPAN	NORTH AMERICA	EUROPE	GENERAL AREA	CHINA
Model Name		FW-85BZ30L	FW-85BZ30L	FW-85BZ30L	FW-85BZ30L	FW-85BZ30L
SV No.		SV-41551	SV-41401	SV-41481	SV-41482	SV-41509
DIMENSION	TV only (W x H x D)	189.9 x 108.9 x 7.1 cm	1899 x 1089 x 71 mm / 74 7/8 x 42 7/8 x 2 7/8 inch	Approx. 189.9 x 108.9 x 7.1 cm	Approx. 1899 x 1089 x 71 mm	Approx. 1899 x 1089 x 71 mm
	TV only with camera (W x H x D)	-	-	-	-	-
	TV with Stand (Standard position) (W x H x D)	189.9 x 117.6 x 45.6 cm	1899 x 1176 x 456 mm / 74 7/8 x 46 3/8 x 18 inch	Approx. 189.9 x 117.6 x 45.6 cm	Approx. 1899 x 1176 x 456 mm	Approx. 1899 x 1176 x 456 mm
	TV with Stand (Narrow position) (W x H x D)	-	-	-	-	-
	TV with Stand (Soundbar position) (W x H x D)	-	-	-	-	-
	TV with Stand (Front position style) (W x H x D)	-	-	-	-	-
	TV with Stand (Back position style) (W x H x D)	-	-	-	-	-
	TV with Floor Stand (W x H x D)	-	-	-	-	-
	Stand Width (Standard position)	153.2 cm	1532 mm / 60 3/8 inch	Approx. 153.2 cm	Approx. 1532 mm	Approx. 1532 mm
	Stand Width (Narrow position)	-	-	-	-	-
	Stand Width (Soundbar position)	-	-	-	-	-
	Stand Width (Front position style)	-	-	-	-	-
	Stand Width (Back position style)	-	-	-	-	-
	Floor Stand Width	-	-	-	-	-
VESA Hole Pitch	40.0 x 40.0 cm	400 x 400 mm / 15 3/4 x 15 3/4 inch	40.0 x 40.0 cm	400 x 400 mm	400 x 400 mm	
WEIGHT	TV Only	44.5 kg	44.5 kg / 98.1 lb	Approx. 44.5 kg	Approx. 44.5 kg	Approx. 44.5 kg
	TV with Stand (Standard position)	46 kg	46 kg / 101.4 lb	Approx. 46 kg	Approx. 46 kg	Approx. 46 kg
	TV with Stand (Narrow position)	-	-	-	-	-
	TV with Stand (Soundbar position)	-	-	-	-	-
	TV with Stand (Front/Back position style)	-	-	-	-	-
	TV with Floor Stand	-	-	-	-	-
	Floor Stand weight (Supply)	-	-	-	-	-
Remarks			Optional stand	Optional stand		

WITH STAND

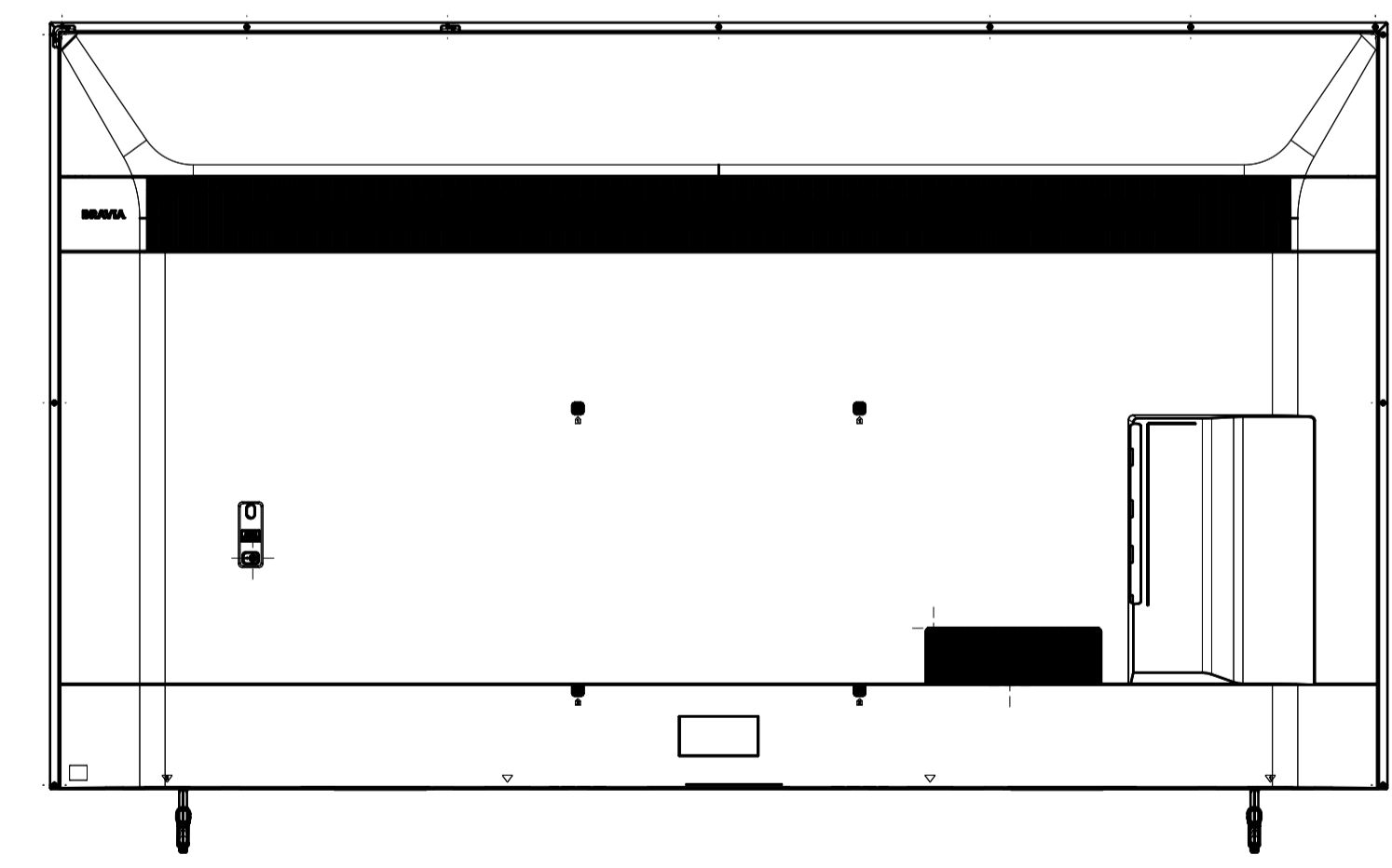
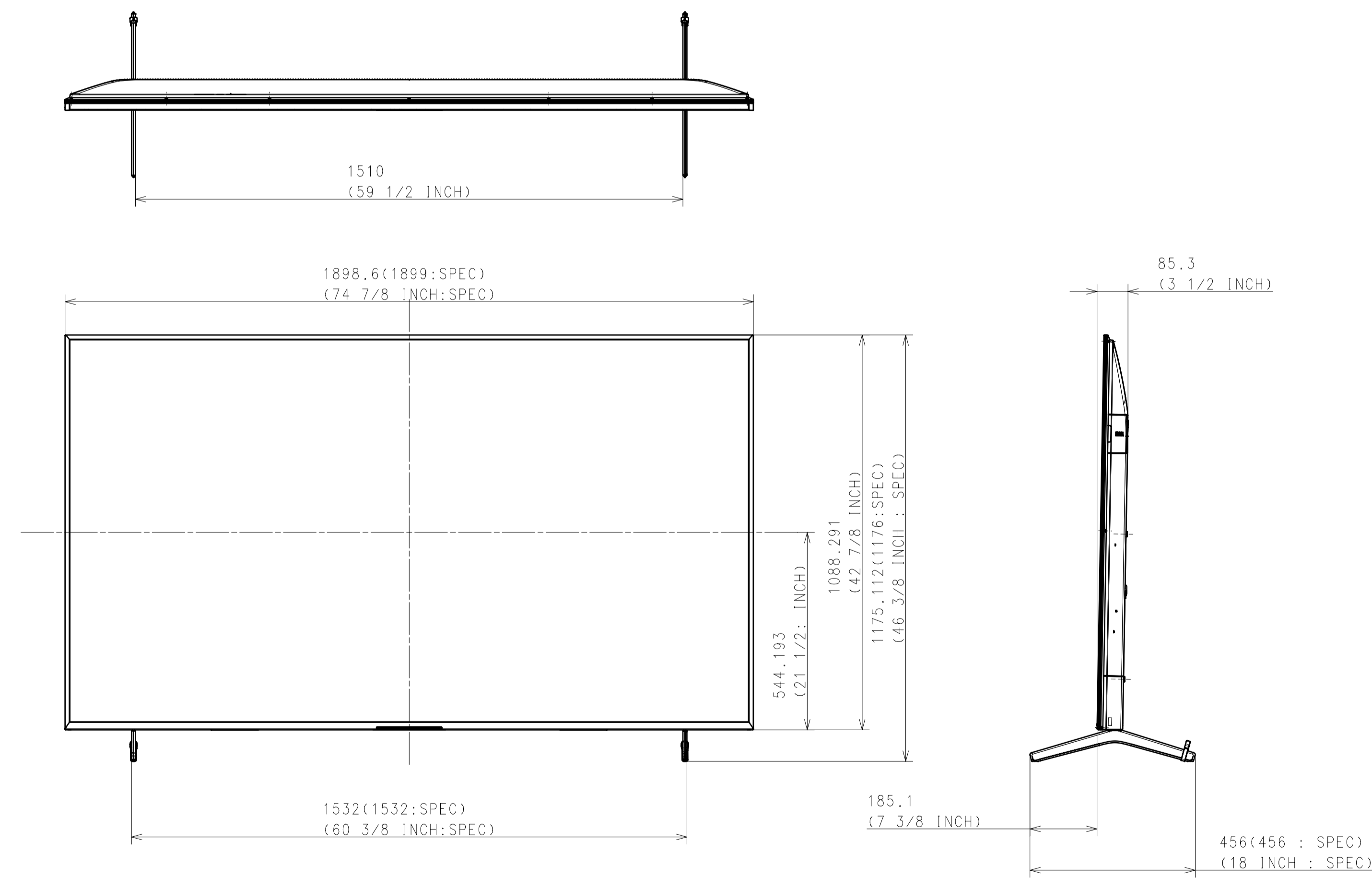

Purchase recycled resins and wire rods only from the business partners that Sony approves as Green Partners.
再生樹脂・電線電纜はグリーンパートナー認定製品から調達すること。

DATE OF ISSUE 2023.01.09	DOCUMENT TYPE ASSEMBLY	GENERAL TOLERANCE	FINISH(COLOR)
REVISION	SIGN.	MATERIAL(COLOR)	FINISH(COLOR)
RESPONSIBLE DEPARTMENT PANEL & MECHANICAL DESIGN		ORIGINAL MODEL 85(BZ30L) EXTERIOR VIEW	DESCRIPTION 85(BZ30L) EXTERIOR VIEW
PLANNED BY	CHECKED BY	APPROVED BY	SCALE 1:10
DATE	DATE	DATE	TENTATIVE MODEL
LEGAL OWNER Sony Corporation	REVISION	DATE	SIZE A1
REVISION	DATE	DATE	UNIT mm
REVISION	DATE	DATE	PAGE NO.
REVISION	DATE	DATE	SUFFIX
REVISION	DATE	DATE	REV. NO.
REVISION	DATE	DATE	SHEET/PAGES 1/3

WITHOUT STAND

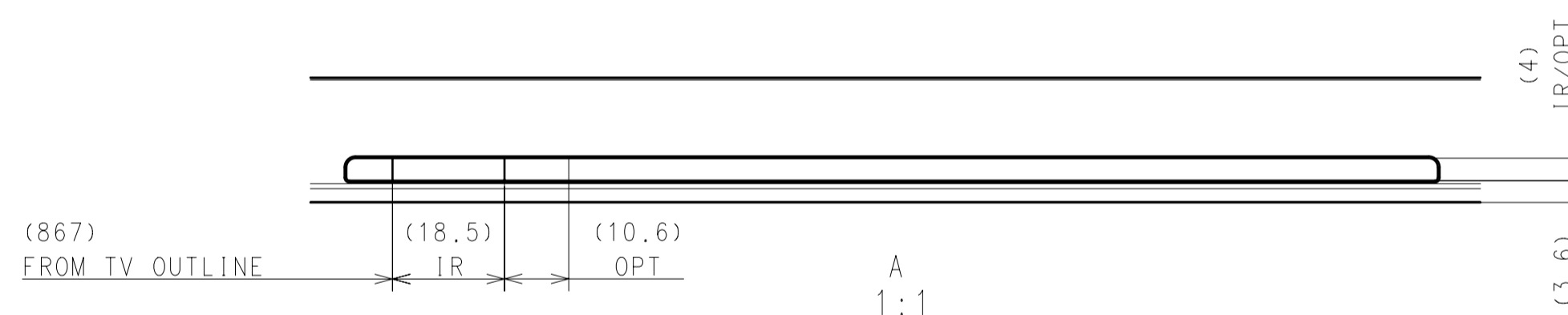
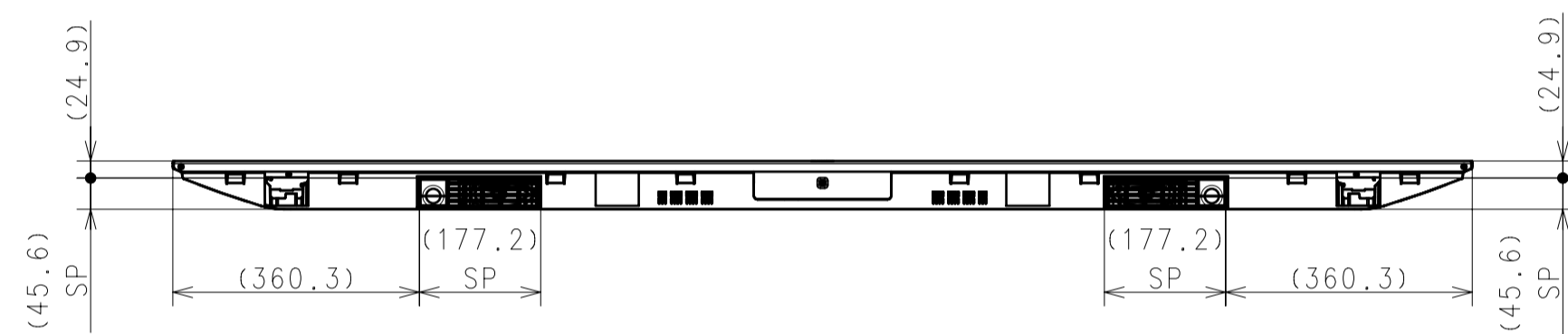
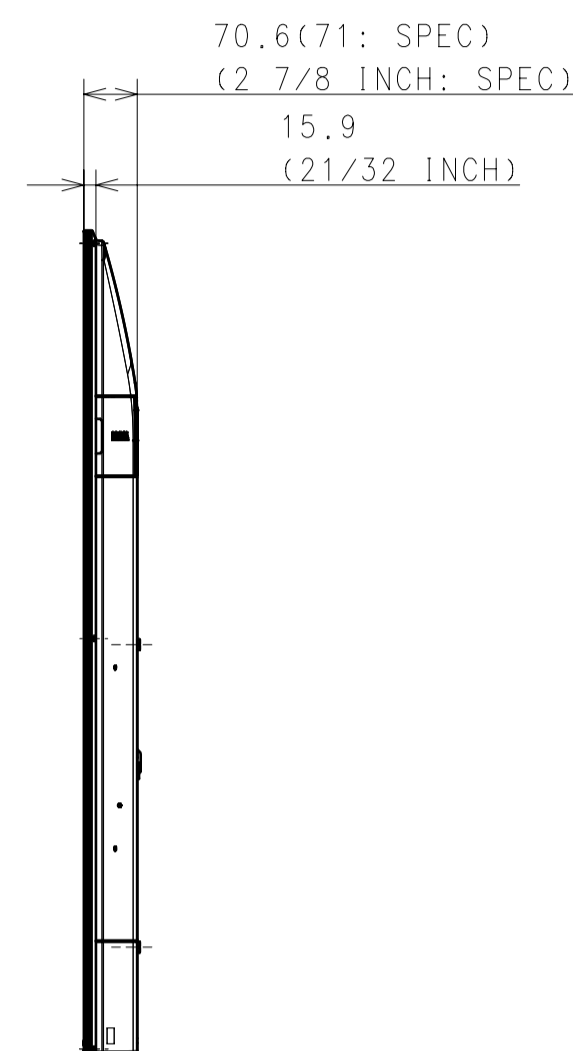
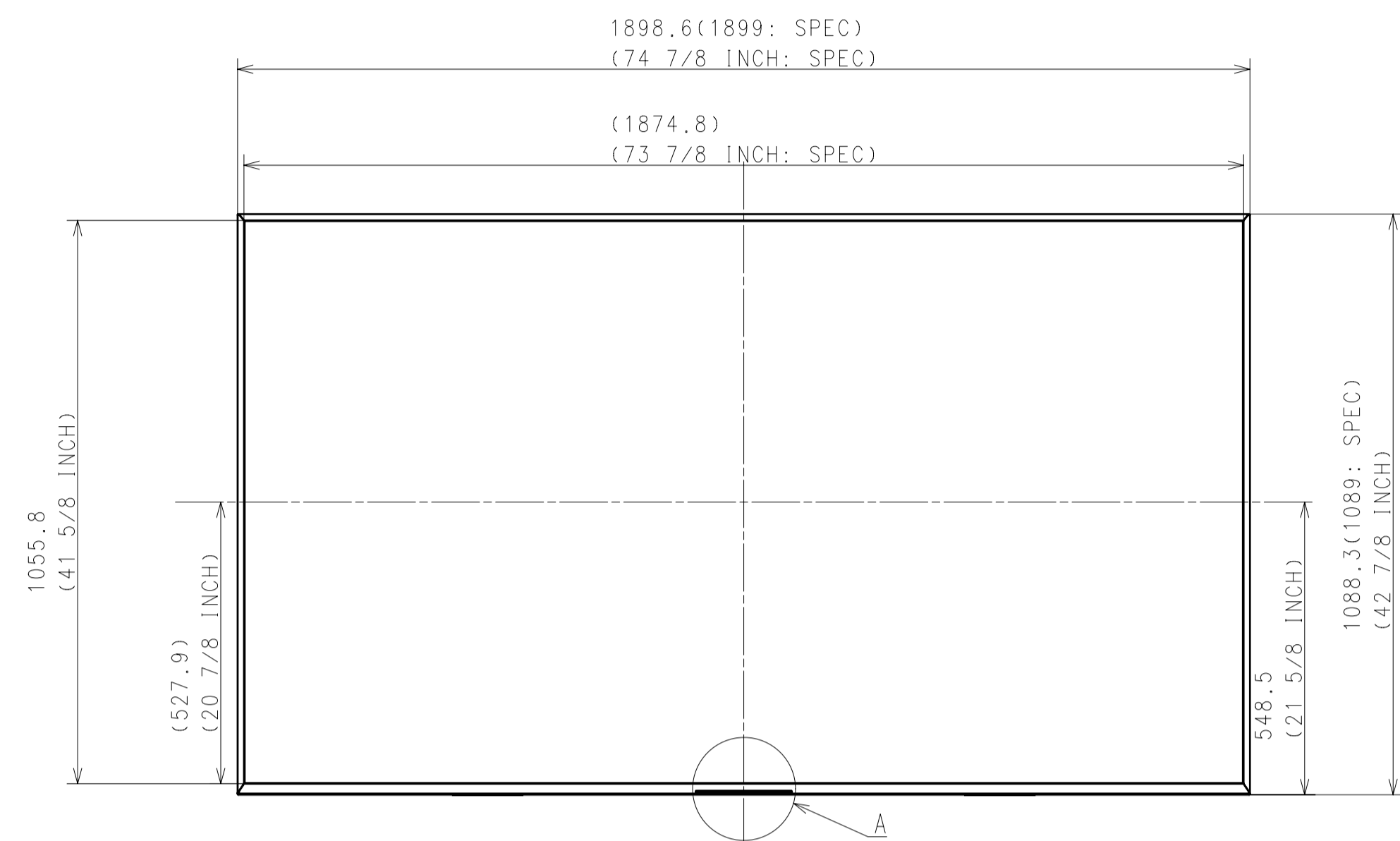

A
1:1

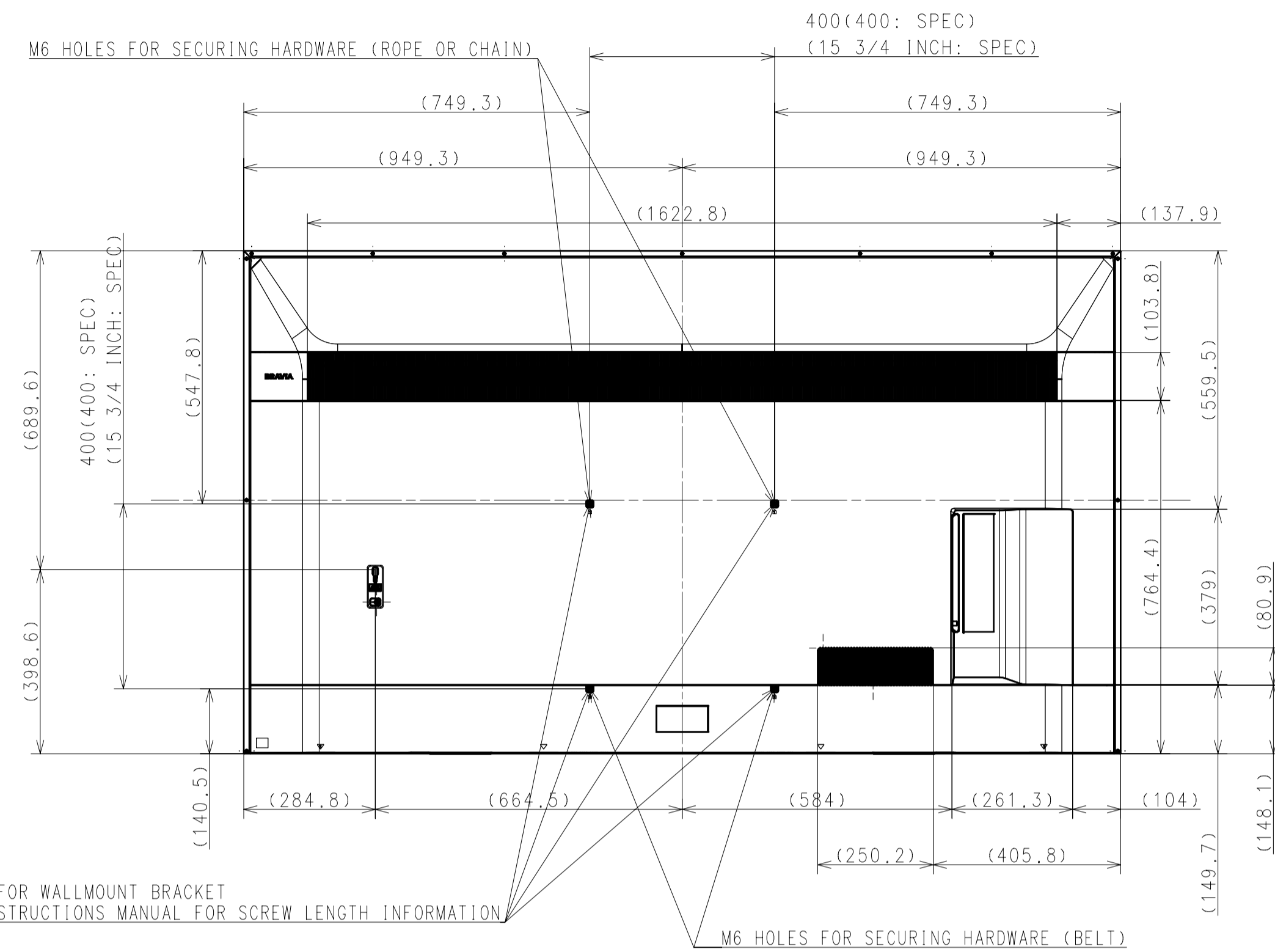

M6 HOLES FOR WALLMOUNT BRACKET
#REFER INSTRUCTIONS MANUAL FOR SCREW LENGTH INFORMATION

M6 HOLES FOR SECURING HARDWARE (BELT)

For NORTH AMERICA, EUROPE, GENERAL AREA, CHINA

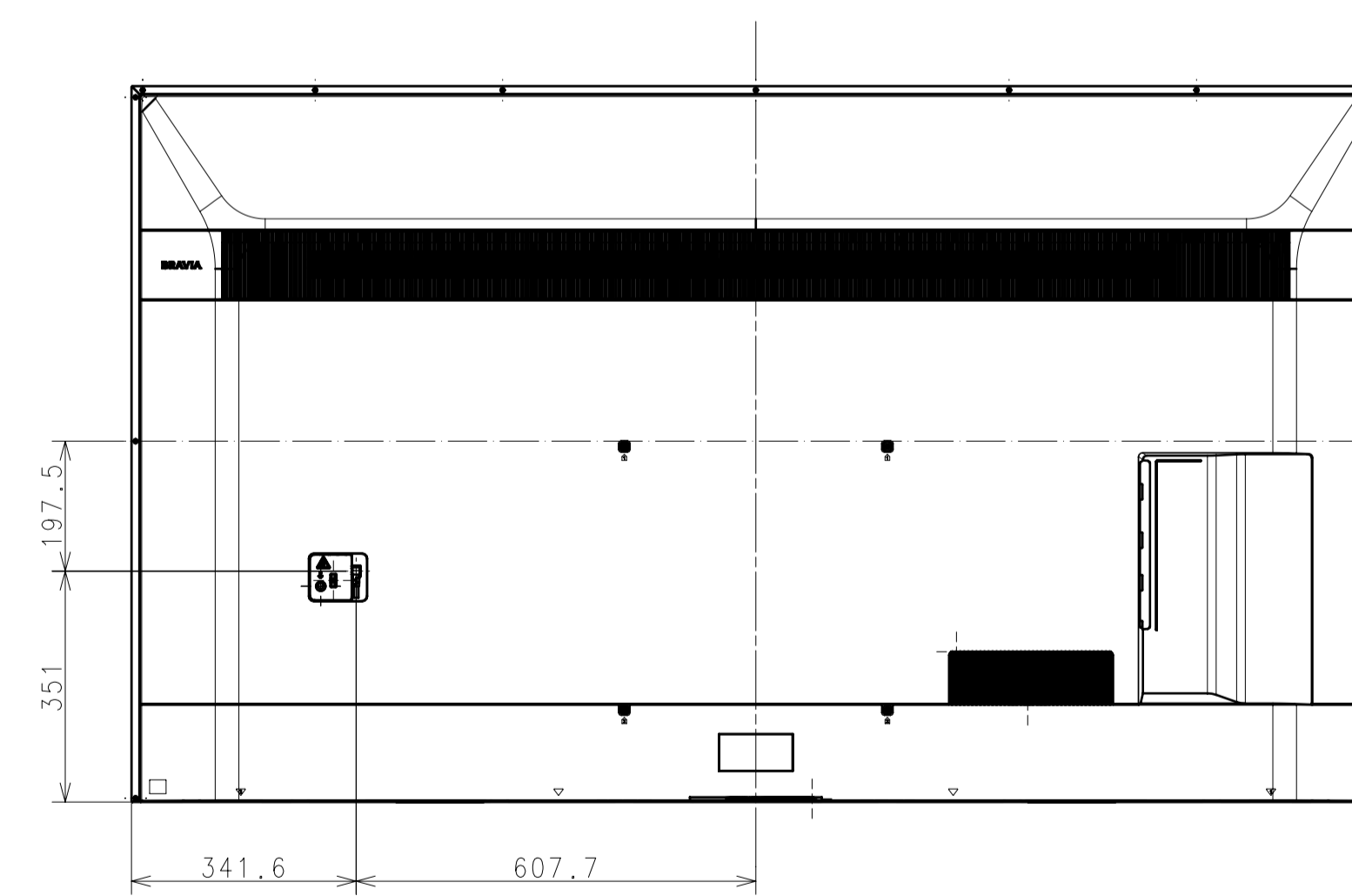

For JAPAN

DESCRIPTION 1	85(BZ30L) EXTERIOR VIEW	LEGAL OWNER	Sony Corporation	SCALE	1:1
DESCRIPTION 2	85(BZ30L) EXTERIOR VIEW	PART NO.		SHEET/PAGES	2 / 3

SU_WL450 SLIM

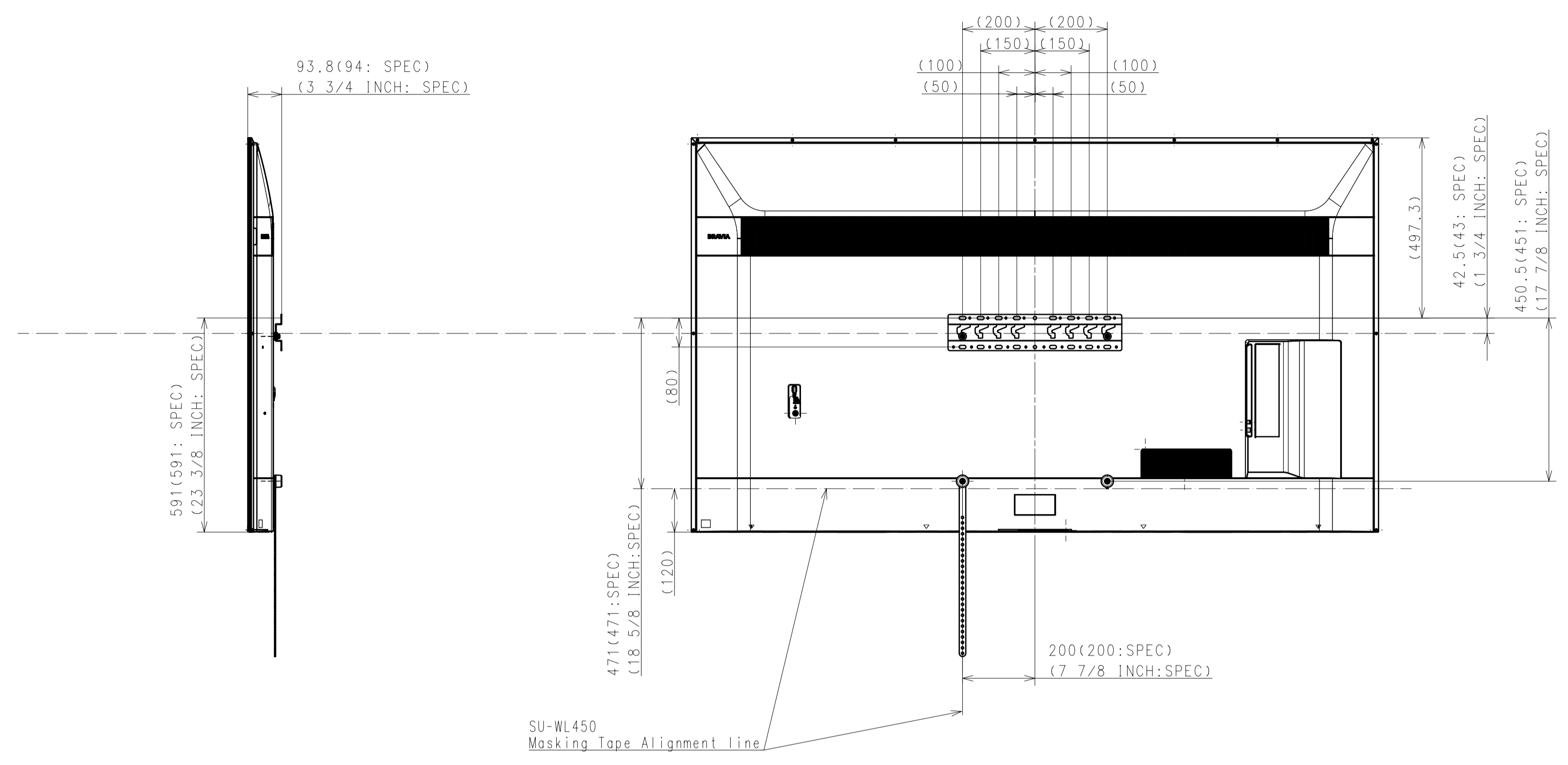

SU_WL450 STANDARD

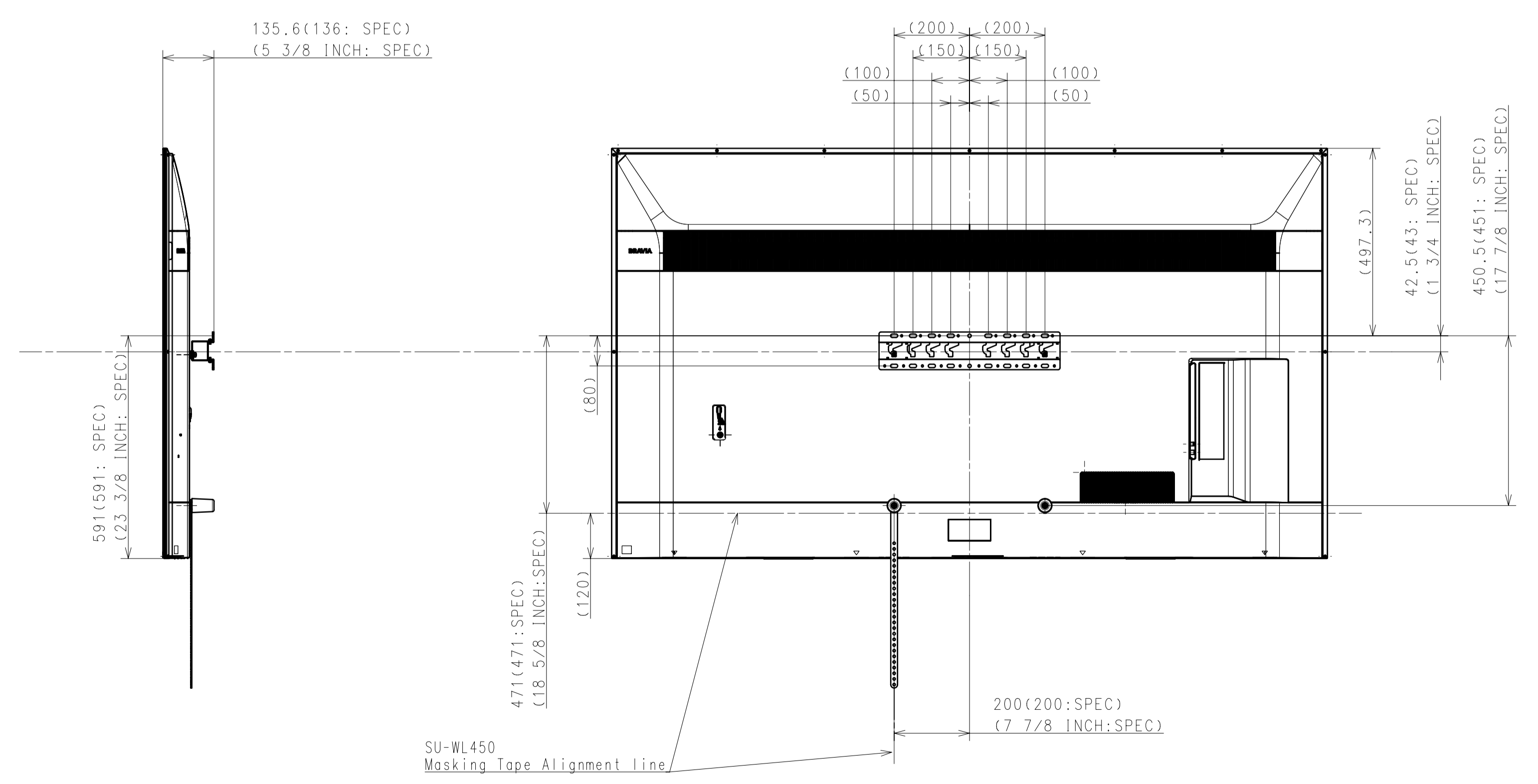

DESCRIPTION	LEGAL OWNER	SCALE
85(BZ30L) EXTERIOR VIEW	Sony Corporation	1:1
85(BZ30L) EXTERIOR VIEW	PART NO.	SHEET/PAGES 3 / 3